



belmetal

Produtos e Soluções em Alumínio

CONSTRUÇÃO CIVIL

Portfólio Nacional 2019

PERFIS

Versão 1.0



Praticidade. Esta é a vertente que a **BELMETAL** almeja alcançar com a criação deste novo catálogo de perfis.

O Portfólio Nacional foi desenvolvido com o intuito de otimizar a vasta quantidade de perfis disponíveis em nossos catálogos.

Com esse trabalho, definiu-se de maneira prática e objetiva a construção das tipologias mais adotadas pelo mercado, utilizando-se do menor número de perfis nas composições. Essa otimização gera um ganho na produtividade e uma redução considerável no número de itens estocados.

Os campos localizados abaixo dos perfis, contém as seguintes informações:

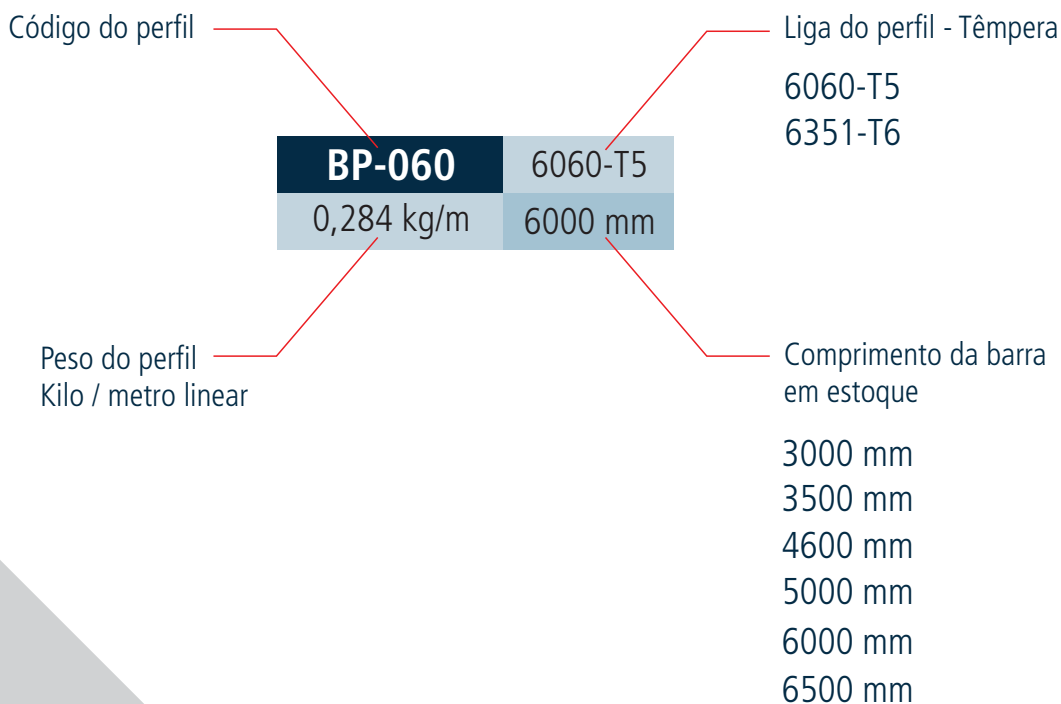



TIPOLOGIAS	TI- 0.01 a 0.07
LINHAS CONVENCIONAIS	
TABELADOS	PE- 1.01 e 1.02
CONTRAMARCOS / ARREMATES / CONEXÕES	PE- 2.01 e 2.02
VENEZIANAS	PE- 3.01 e 3.02
LINHA 42	PE- 4.01
COMPLEMENTOS	PE- 5.01 e 5.02
SISTEMAS	
IMPERIAL 2.5	PE- 6.01 a 6.15
IMPERIAL 3.5 SLIM	PE- 7.01 a 7.13
INTEGRADA	PE- 8.01 a 8.06
SUPERIA	PE- 9.01 e 9.02
STILOGRAD	PE-10.01
GRIDSKY	PE-11.01 e 11.02
FACHADA ATLANTAPE-12.01 a 12.17



TIPOLOGIAS

As informações contidas neste catálogo são de propriedade da BELMETAL e estão sujeitas a alterações sem aviso prévio. Verifique o site www.belmetal.com.br para obter a versão mais atualizada.

Janelas de correr

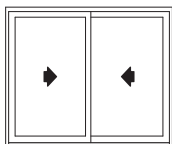

Janela de correr 2 folhas

Imperial 2.5 Imperial 3.5 S
Superia

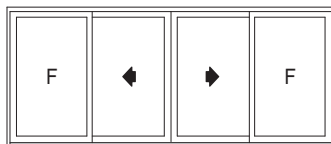

Janela de correr 4 folhas

Imperial 2.5 Imperial 3.5 S
Superia

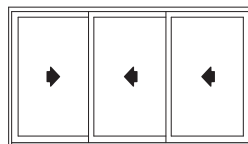

Janela de correr 3 folhas

Imperial 2.5 Imperial 3.5 S
Superia

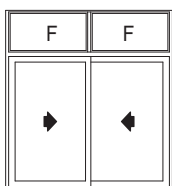

Janela de correr 2 folhas com bandeira fixa

Imperial 2.5 Imperial 3.5 S

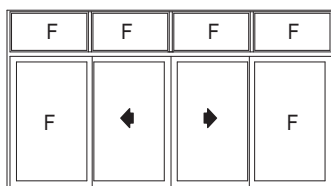

Janela de correr 4 folhas com bandeira fixa

Imperial 2.5 Imperial 3.5 S

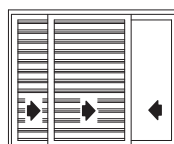

Janela de correr 3 folhas com veneziana cega / ventilada / vidro

Imperial 2.5

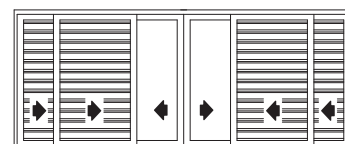

Janela de correr 6 folhas com veneziana cega / ventilada / vidro

Imperial 2.5

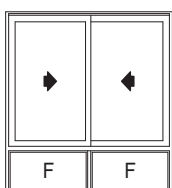

Janela de correr 2 folhas com peitoril fixo

Imperial 2.5 Imperial 3.5 S

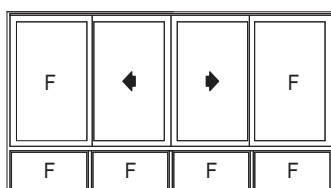

Janela de correr 4 folhas com peitoril fixo

Imperial 2.5

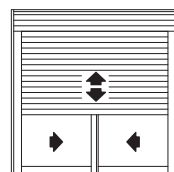

Janela de correr 2 folhas com persiana integrada

Imperial 2.5 Imperial 3.5 S

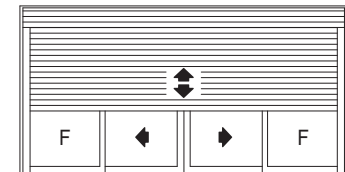

Janela de correr 4 folhas com persiana integrada

Imperial 2.5 Imperial 3.5 S

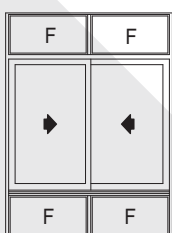

Janela de correr 2 folhas com bandeira e peitoril fixos

Imperial 2.5 Imperial 3.5 S

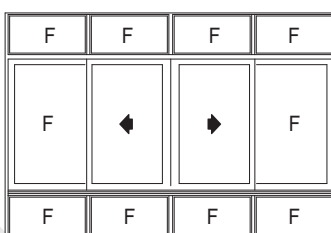

Janela de correr 4 folhas com bandeira e peitoril fixos

Imperial 2.5 Imperial 3.5 S

Janelas maxim-ar

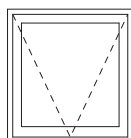

Janela maxim-ar 1 folha

Imperial 2.5 Imperial 3.5 S

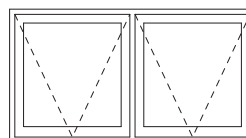

Janela maxim-ar 2 folhas

Imperial 2.5 Imperial 3.5 S

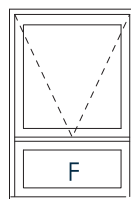

Janela maxim-ar 1 folha
com peitoril fixo

Imperial 2.5 Imperial 3.5 S

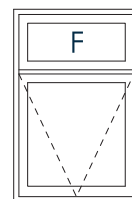

Janela maxim-ar 1 folha
com bandeira fixa

Imperial 2.5 Imperial 3.5 S

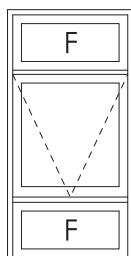

Janela maxim-ar 1 folha com
bandeira e peitoril fixos

Imperial 2.5 Imperial 3.5 S

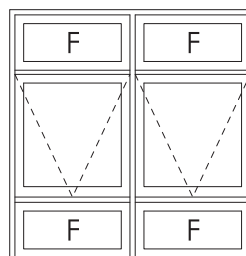

Janela maxim-ar 2 folhas com
bandeira e peitoril fixos

Imperial 2.5 Imperial 3.5 S

Portas de correr

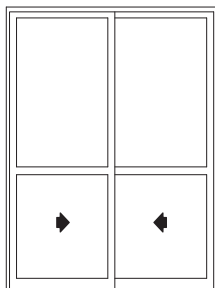

Porta de correr 2 folhas

Imperial 2.5 Imperial 3.5 S
Superia

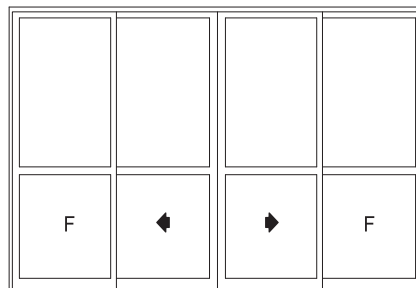

Porta de correr 4 folhas

Imperial 2.5 Imperial 3.5 S
Superia

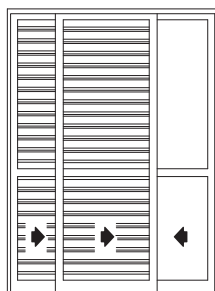

Porta de correr 3 folhas com veneziana cega / ventilada / vidro

Imperial 2.5

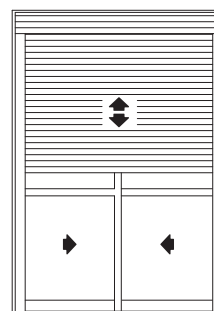

Porta de correr 2 folhas com persiana integrada

Imperial 2.5 Imperial 3.5 S

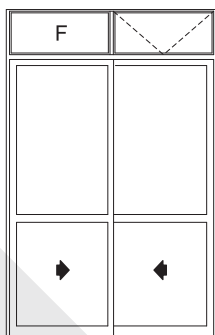

Porta de correr 2 folhas com bandeira fixa e maxim-ar

Imperial 2.5 Imperial 3.5 S

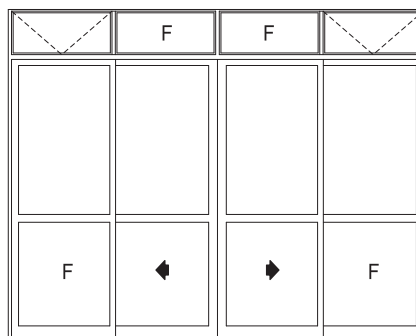

Porta de correr 4 folhas com bandeira fixa e maxim-ar

Imperial 2.5 Imperial 3.5 S

Portas de giro

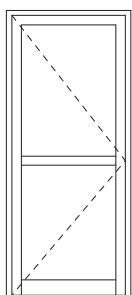

Porta de giro 1 folha

Imperial 2.5 Imperial 3.5 S
Linha 42

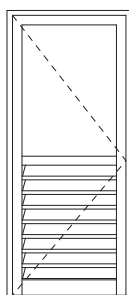

Porta de giro 1 folha
com veneziana / vidro

Imperial 2.5 Imperial 3.5 S

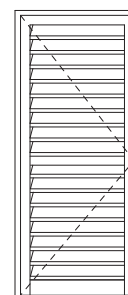

Porta de giro 1 folha
com veneziana

Imperial 2.5 Imperial 3.5 S

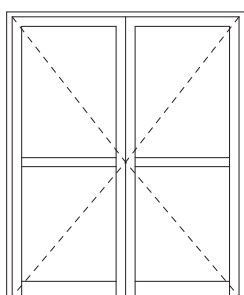

Porta de giro 2 folhas

Imperial 2.5 Imperial 3.5 S
Linha 42

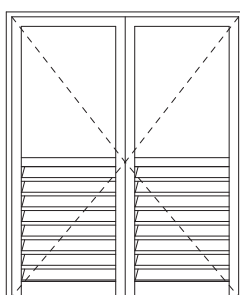

Porta de giro 2 folhas
com veneziana / vidro

Imperial 2.5 Imperial 3.5 S

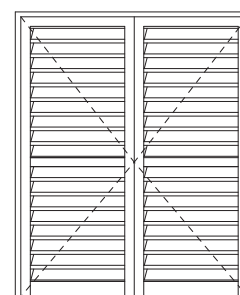

Porta de giro 2 folhas
com veneziana

Imperial 2.5 Imperial 3.5 S

Fachada Cortina

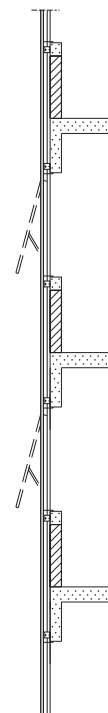
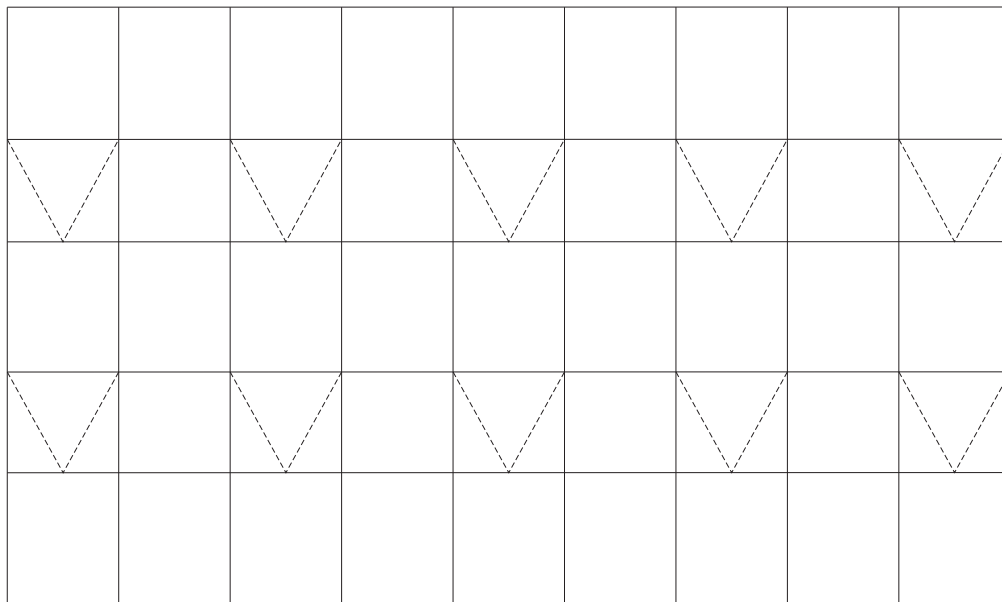

Pele de vidro /
Structural glazing

Atlanta

Fachada Entre-vão

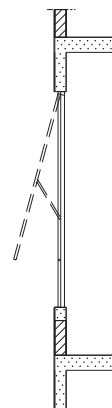
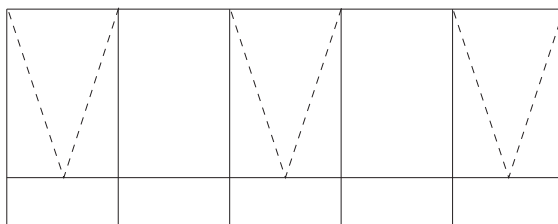

Pele de vidro /
Structural glazing

Atlanta

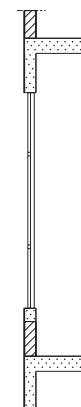
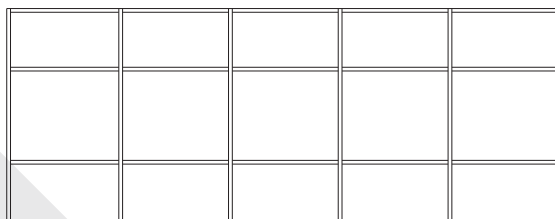

Pele de vidro

GridSky

As informações contidas neste catálogo são de propriedade da BELMETAL e estão sujeitas a alterações sem aviso prévio. Verifique o site www.belmetal.com.br para obter a versão mais atualizada.

Guarda-corpo

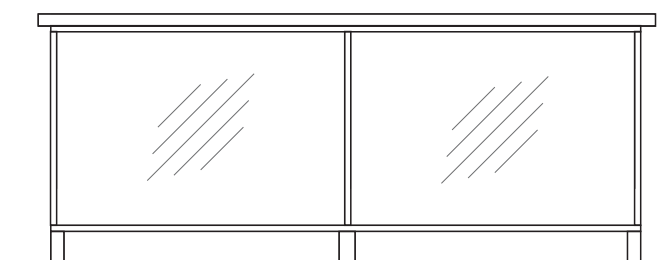

Guarda-corpo com vidro

StiloGrad

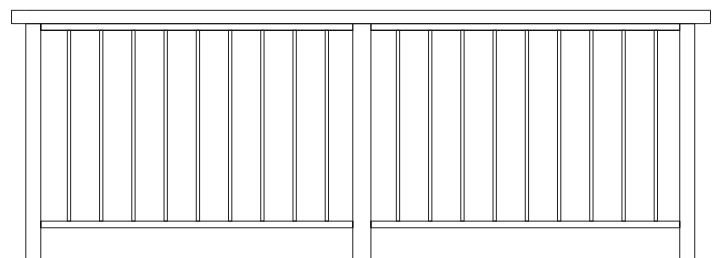

Guarda-corpo com barrote

StiloGrad



PERFIS

As informações contidas neste catálogo são de propriedade da BELMETAL e estão sujeitas a alterações sem aviso prévio. Verifique o site www.belmetal.com.br para obter a versão mais atualizada.

Barra retangular



Código	Peso	Dimensões (mm)		Dimensões (pol)	
Perfil	kg / m	A	B	A	B
BR-403	0,109	12,70	3,17	1/2"	1/8"
BR-408	0,204	15,87	4,76	5/8"	3/16"
BR-412	0,245	19,05	4,76	3/4"	3/16"
BR-419	0,217	25,40	3,17	1"	1/8"
BR-420	0,326	25,40	4,76	1"	3/16"
BR-421	0,435	25,40	6,35	1"	1/4"
BR-422	0,653	25,40	9,52	1"	3/8"
BR-429	0,816	31,75	9,52	1 1/4"	3/8"
BR-454E	0,810	100,00	3,00	-	-

Liga = 6060-T5

Comprimento da barra = 6.000 mm

Cantoneira abas iguais

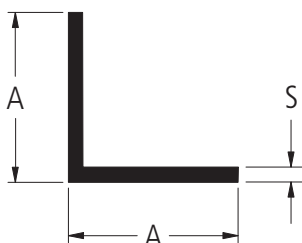

Código	Peso	Dimensões (mm)		Dimensões (pol)	
Perfil	kg / m	A	S	A	S
PL-152	0,102	12,70	1,58	1/2"	1/16"
PL-155	0,129	15,87	1,58	5/8"	1/16"
PL-157	0,156	19,05	1,58	3/4"	1/16"
PL-160	0,271	22,22	2,38	7/8"	3/32"
PL-162	0,210	25,40	1,58	1"	1/16"
PL-163	0,408	25,40	3,17	1"	1/8"
PL-228	0,318	38,10	1,58	1 1/2"	1/16"
PL-167	0,625	38,10	3,17	1 1/2"	1/8"
PL-183E	0,671	50,80	2,50	2"	-
PL-169	0,842	50,80	3,17	2"	1/8"

Liga = 6060-T5

Comprimento da barra = 6.000 mm

Cantoneira abas desiguais

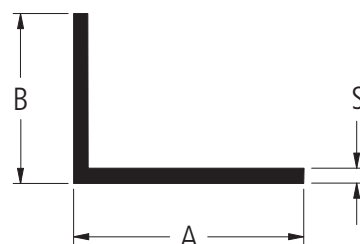

Código	Peso	Dimensões (mm)			Dimensões (pol)		
Perfil	kg / m	A	B	S	A	B	S
PL-255	0,625	50,80	25,40	3,17	2"	1"	1/8"

Liga = 6060-T5

Comprimento da barra = 6.000 mm

U abas iguais

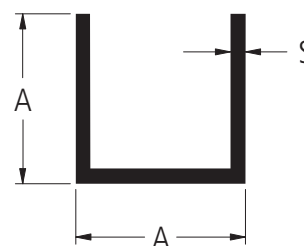

Código	Peso	Dimensões (mm)		Dimensões (pol)	
Perfil	kg / m	A	S	A	S
PU-101	0,108	9,52	1,58	3/8"	1/16"
PU-102	0,149	12,70	1,58	1/2"	1/16"
PU-104	0,182	16,00	1,50	-	-
PU-112	0,583	26,00	3,00	-	-

Liga = 6060-T5

Comprimento da barra = 6.000 mm

U abas desiguais

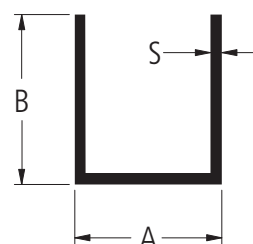

Código	Peso	Dimensões (mm)			Dimensões (pol)		
Perfil	kg / m	A	B	S	A	B	S
3213	0,389	29,00	35,00	1,5	-	-	-

Liga = 6060-T5

Comprimento da barra = 6.000 mm

Tubo quadrado

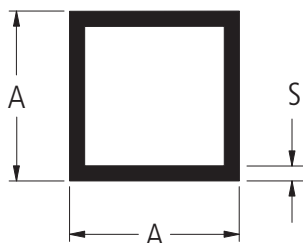

Código	Peso	Dimensões (mm)		Dimensões (pol)	
		A	S	A	S
TQ-001	0,190	12,70	1,58	1/2"	1/16"
TQ-031	0,233	15,90	1,50	-	-
TQ-009	0,284	19,05	1,50	3/4"	-
TQ-012	0,387	25,40	1,50	1"	-
TQ-015	0,593	38,10	1,50	1 1/2"	-
TQ-017	1,054	50,80	2,00	2"	-
TQ-020	1,603	76,20	2,00	3"	-
TQ-056	2,686	101,60	2,50	4"	-

Liga = 6060-T5
Comprimento da barra = 6.000 mm

Tubo retangular

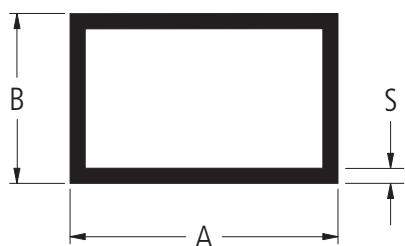

Código	Peso	Dimensões (mm)			Dimensões (pol)		
		A	B	S	A	B	S
TG-060	0,298	25,40	12,70	1,58	1"	1/2"	1/16"
TG-075	0,490	50,80	12,70	1,50	2"	1/2"	-
TG-041	0,400	50,80	25,40	1,00	2"	1"	-
TG-044	0,623	50,80	25,40	1,58	2"	1"	1/16"
TG-038	0,902	76,20	38,10	1,50	3"	1 1/2"	-
TG-039E	1,754	101,60	38,10	2,40	4"	1 1/2"	-
TG-036	1,603	101,60	50,80	2,00	4"	2"	-
TG-046E	3,206	152,40	50,80	3,00	6"	2"	-

Liga = 6060-T5
Comprimento da barra = 6.000 mm

Tubo redondo

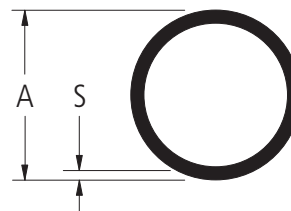

Código	Peso	Dimensões (mm)		Dimensões (pol)	
		A	S	A	S
TR-049	0,191	15,87	1,58	5/8"	1/16"
TR-053	0,234	19,05	1,58	3/4"	1/16"
TR-058	0,276	22,22	1,58	7/8"	1/16"
TR-061	0,319	25,40	1,58	1"	1/16"
TR-075	0,489	38,10	1,58	1 1/2"	1/16"
TR-085E	0,670	50,80	1,60	2"	-
TR-099	1,263	76,20	2,00	3"	-

Liga = 6060-T5
Comprimento da barra = 6.000 mm

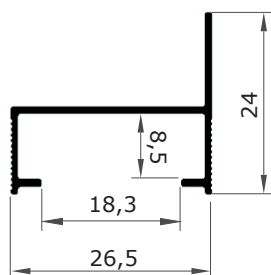

BP-384E	6060-T5
0,175 kg/m	6000 mm

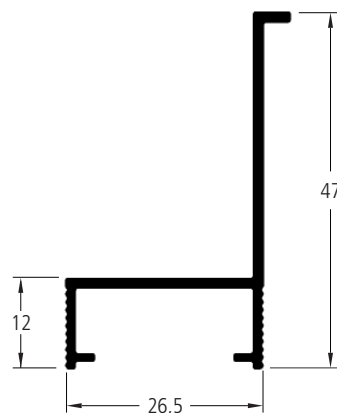

BP-055E	6060-T5
0,333 kg/m	6000 mm

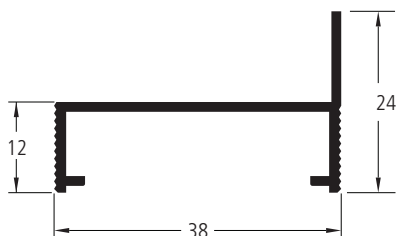

BP-060E	6060-T5
0,223 kg/m	6000 mm

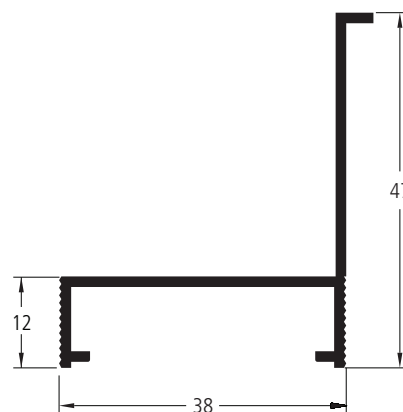

BP-098E	6060-T5
0,377 kg/m	6000 mm

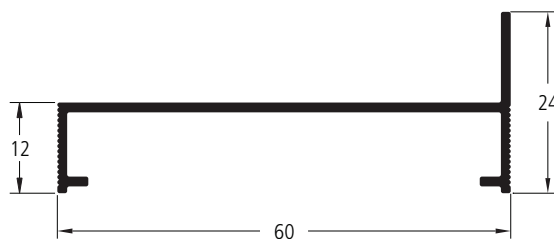

BS-699E	6060-T5
0,391 kg/m	6000 mm

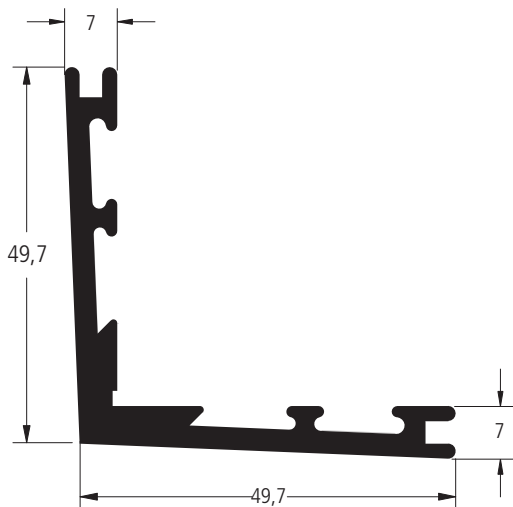

BL-006E	6060-T5
1,006 kg/m	3000 mm

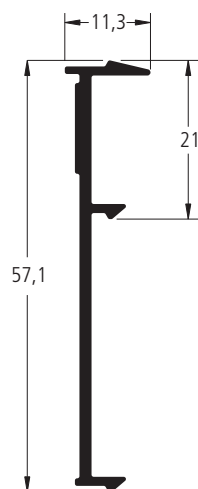

SI-3669	6060-T5
0,328 kg/m	6000 mm

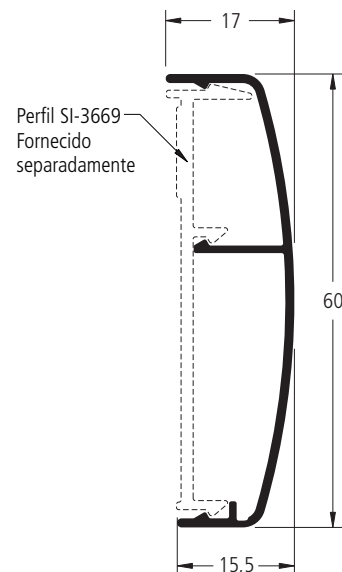

SI-3667	6060-T5
0,308 kg/m	6000 mm

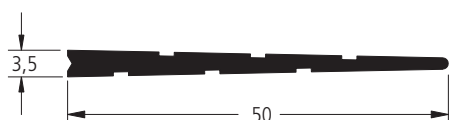

BL-011E	6060-T5
0,315 kg/m	3000 mm

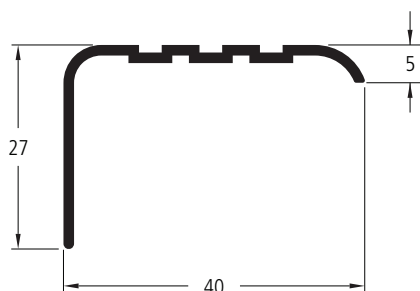

BP-013E	6060-T5
0,268 kg/m	6000 mm

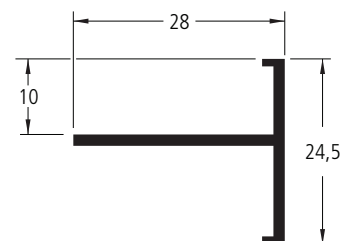

2825	6060-T5
0,219 Kg/m	6000 mm

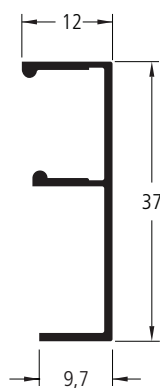

BP-347E	6060-T5
0,197 kg/m	6000 mm

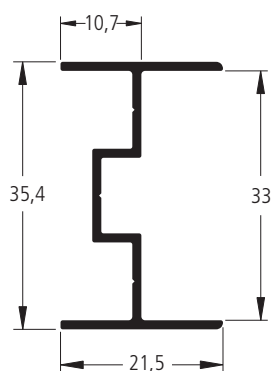

B-466	6060-T5
0,280 kg/m	6000 mm

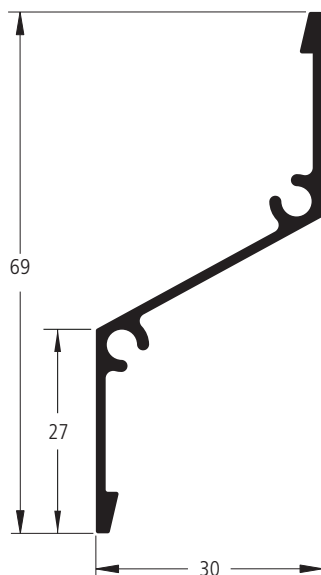

E-565E	6060-T5
0,397 kg/m	6000 mm

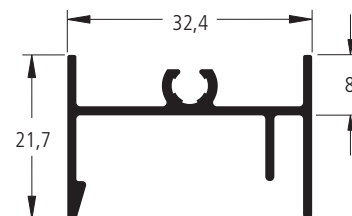

B-467	6060-T5
0,358 kg/m	6000 mm

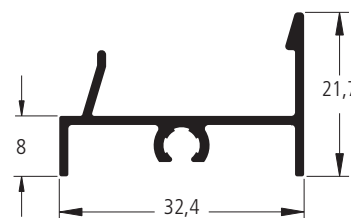

B-468	6060-T5
0,280 kg/m	6000 mm

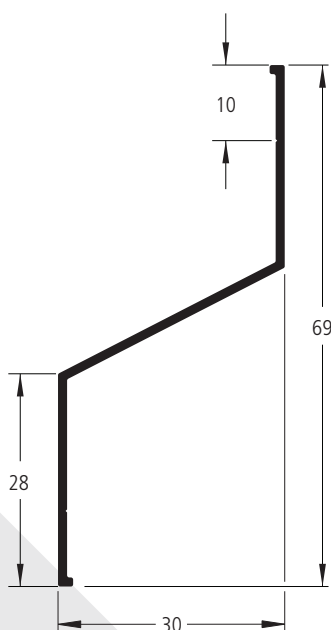

6052E	6060-T5
0,302 kg/m	6000 mm

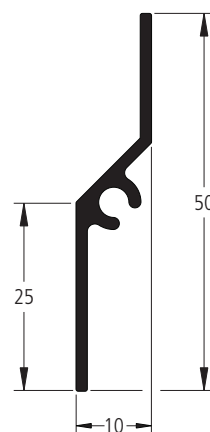

3517E	6060-T5
0,252 kg/m	6000 mm

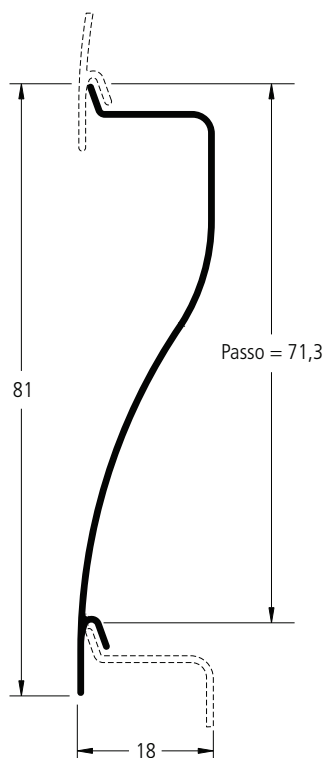

SI-2608	6060-T5
0,254 Kg/m	6000 mm

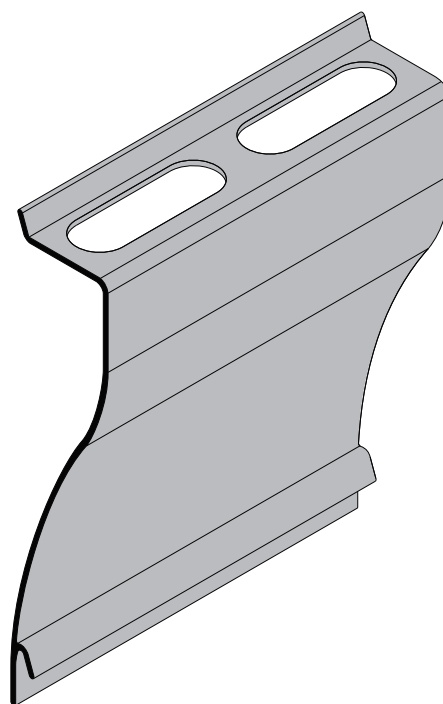

SI-2608V	6060-T5
0,254 Kg/m	6000 mm

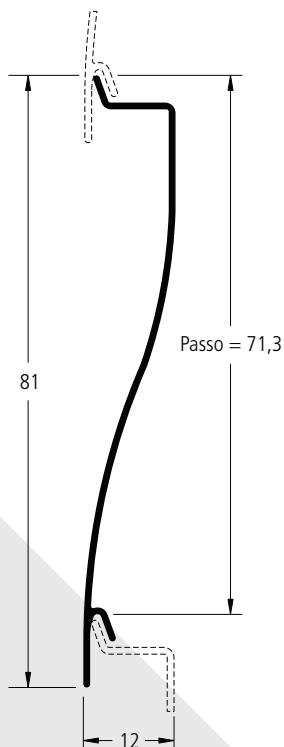

SI-2609	6060-T5
0,236 Kg/m	6000 mm

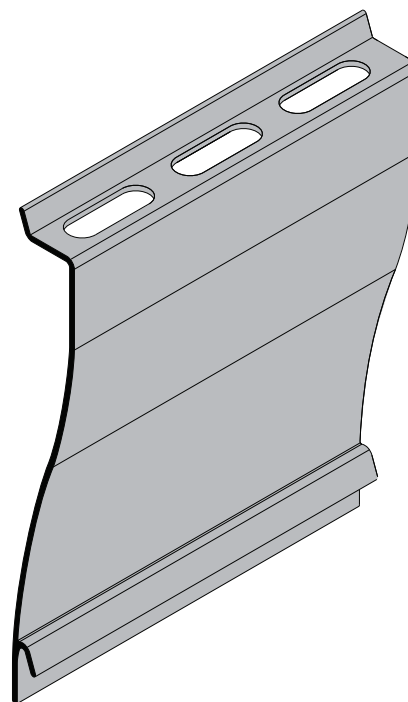

SI-2609V	6060-T5
0,236 Kg/m	6000 mm

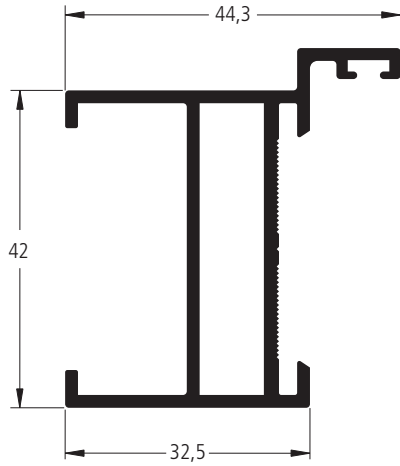

4239E	6060-T5
0,855 kg/m	6000 mm

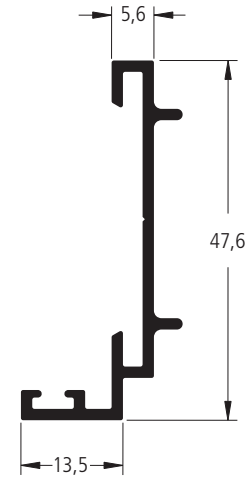

4205E	6060-T5
0,369 kg/m	6000 mm

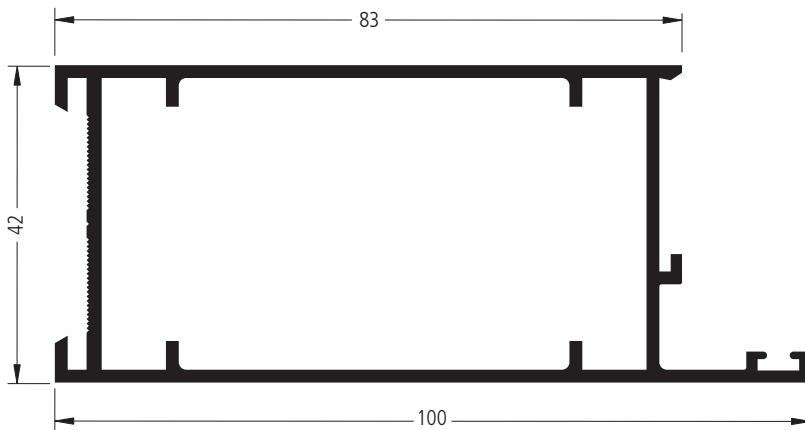

4251E	6060-T5
1,373 kg/m	6000 mm

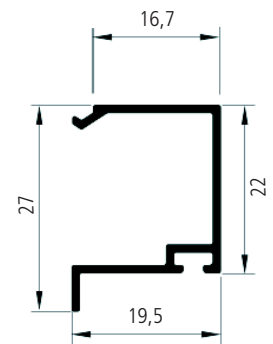

4294	6060-T5
0,209 kg/m	6000 mm

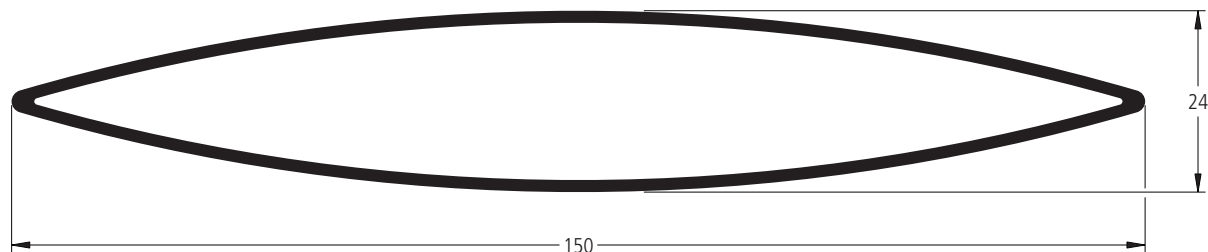

3065E	6060-T5
1,300 kg/m	6000 mm

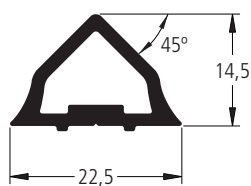

3147E	6060-T5
0,249 kg/m	6000 mm

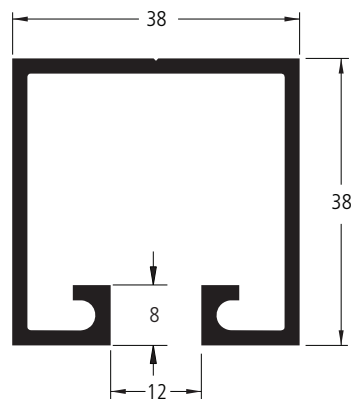

E-560E	6060-T5
0,635 kg/m	6000 mm

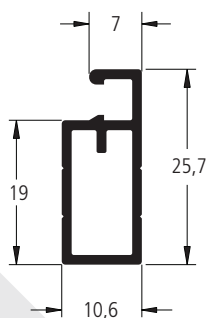

3107	6060-T5
0,245 kg/m	6000 mm

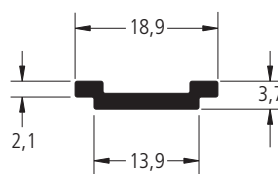

LS-4510	6060-T5
0,118 kg/m	6000 mm

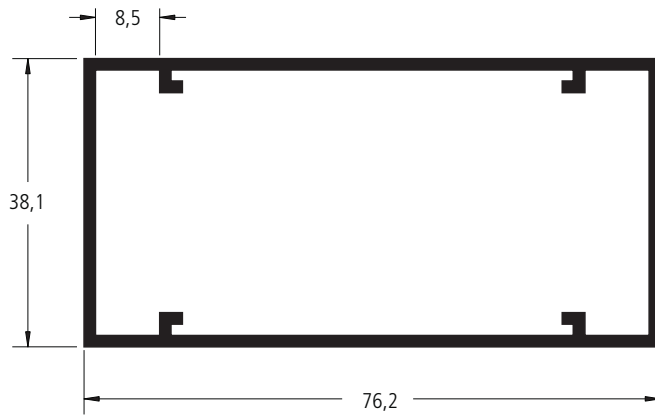

3189E	6060-T5
0,945 Kg/m	6000 mm

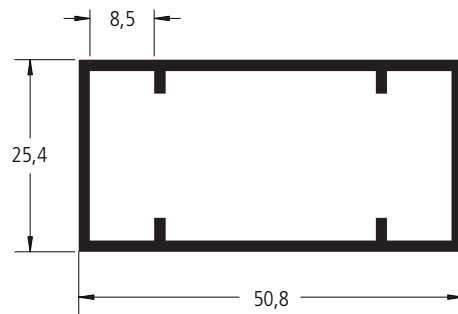

3190E	6060-T5
0,563 Kg/m	6000 mm

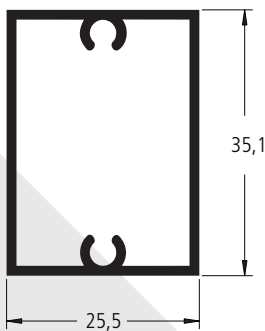

B-405E	6060-T5
0,580 Kg/m	6000 mm

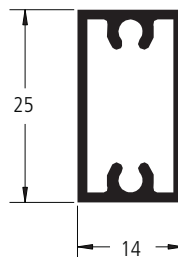

B-413E	6060-T5
0,349 Kg/m	6000 mm

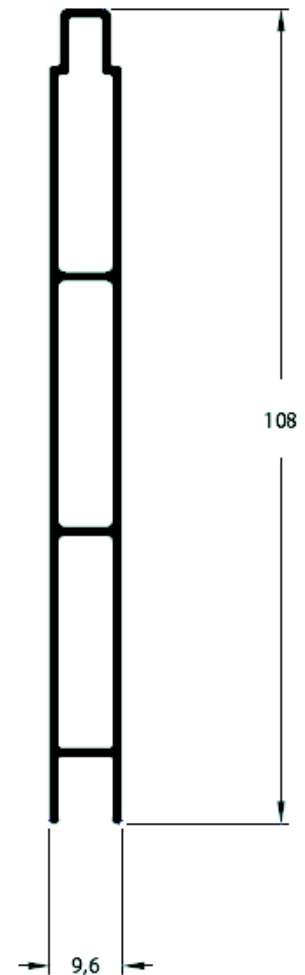

7274E	6060-T5
0,805 Kg/m	6000 mm

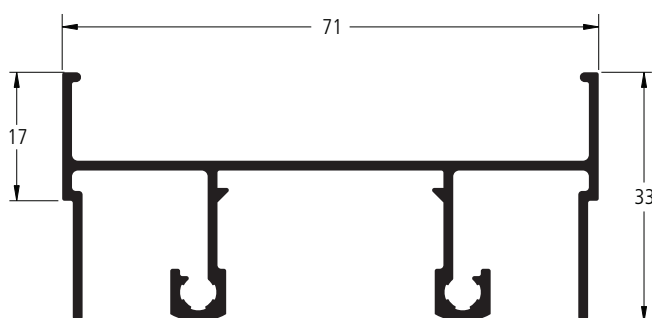

BS-501E	6060-T5
0,773 Kg/m	6000 mm

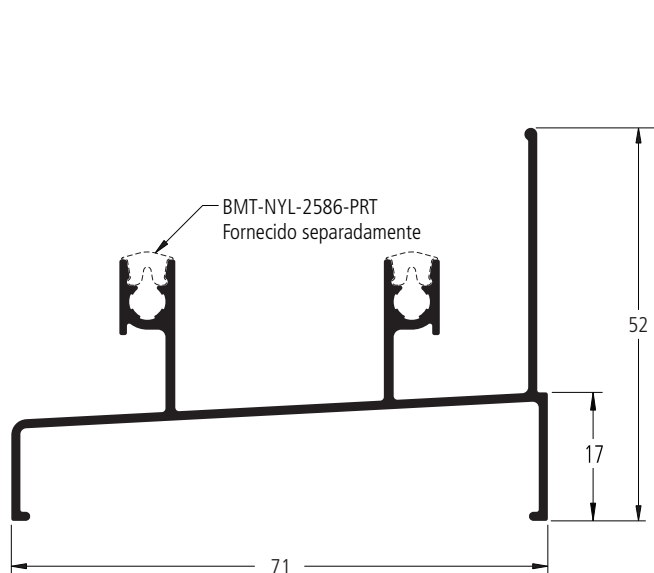

SI-2521	6060-T5
0,705 Kg/m	6000 mm

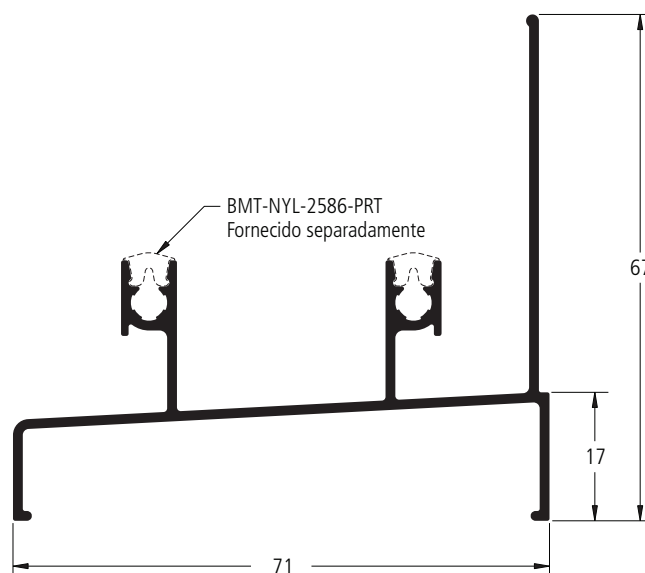

SI-2541	6060-T5
0,791 Kg/m	6000 mm

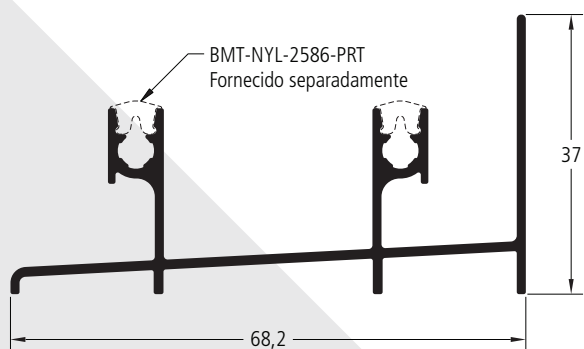

SI-2523	6060-T5
0,650 kg/m	6000 mm

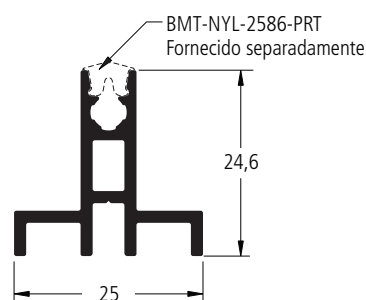

SI-2568	6060-T5
0,360 Kg/m	6000 mm

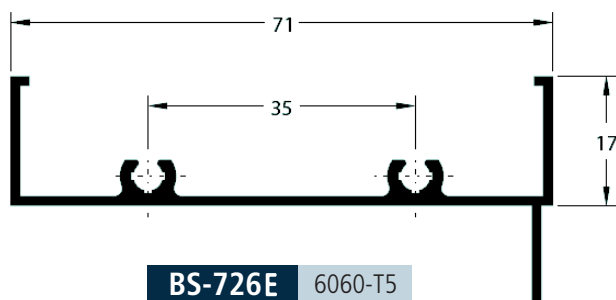

BS-726E	6060-T5
0,526 Kg/m	6000 mm

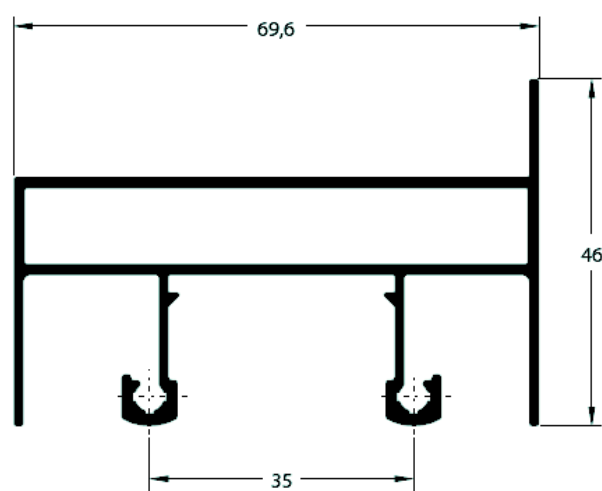

BS-729E	6060-T5
1,106 Kg/m	6000 mm

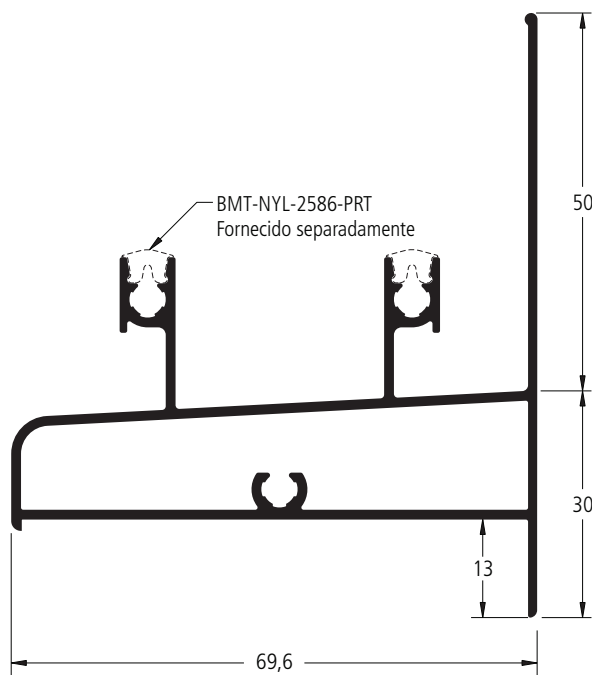

SI-2542	6060-T5
1,150 Kg/m	6000 mm

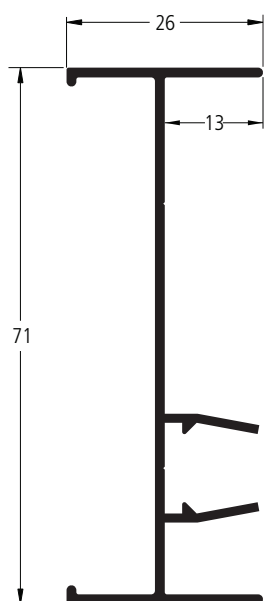

BS-503E	6060-T5
0,537 Kg/m	6000 mm



BS-753E	6060-T5
0,386 Kg/m	6000 mm

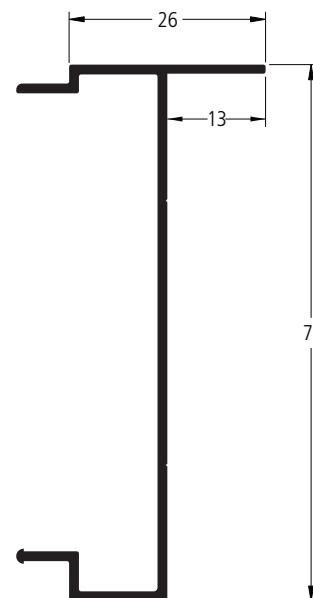

BS-616	6060-T5
0,458 Kg/m	6000 mm

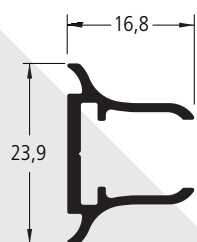

SI-2509	6060-T5
0,229 Kg/m	6000 mm

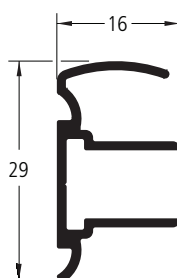

SI-2606	6060-T5
0,264 Kg/m	6000 mm

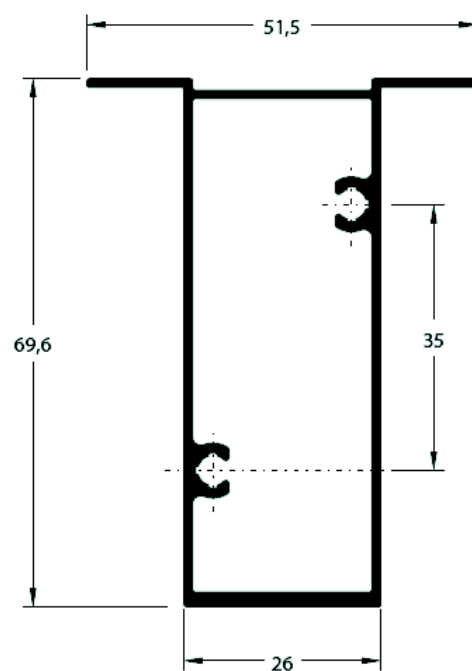

SI-2574E	6060-T5
0,907 Kg/m	6000 mm

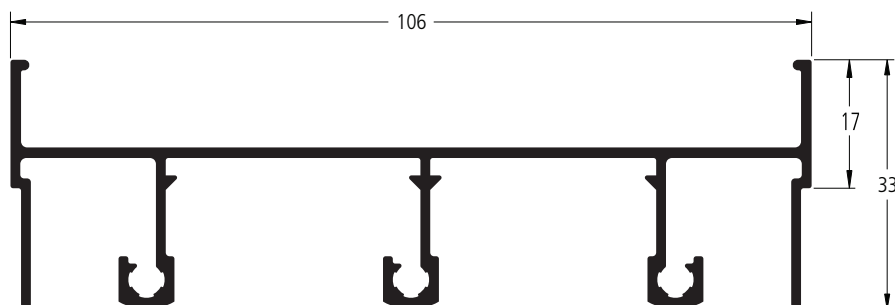

BS-507E	6060-T5
1,028 Kg/m	6000 mm

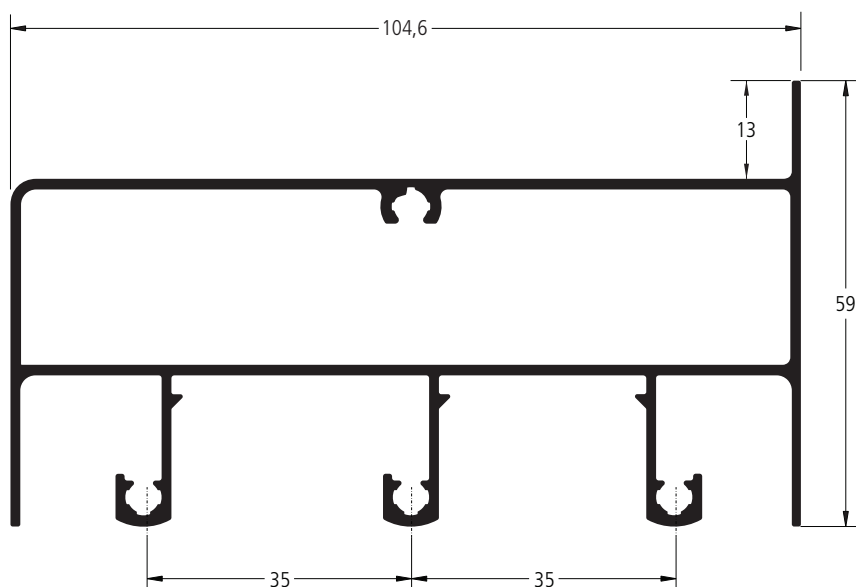

BS-617	6060-T5
2,140 Kg/m	6000 mm

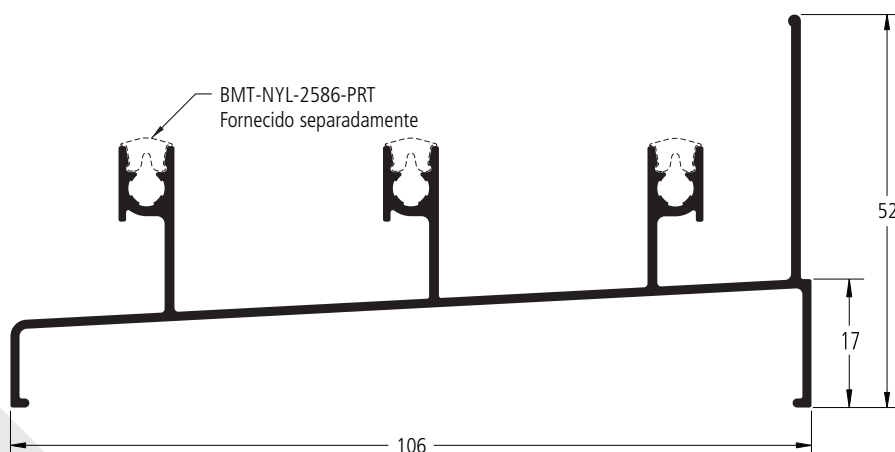

SI-2621	6060-T5
0,989 Kg/m	6000 mm

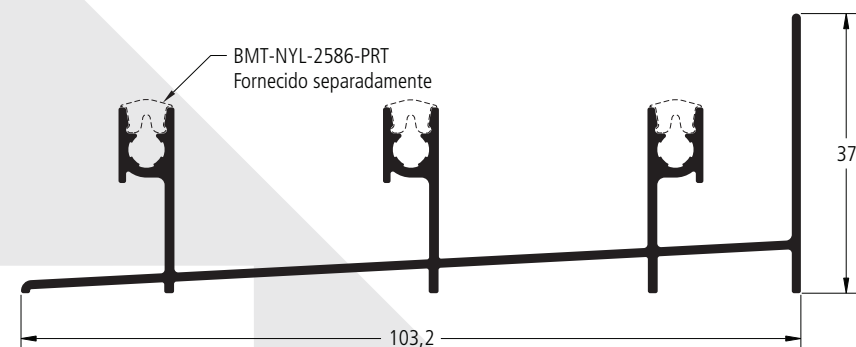

SI-2622	6060-T5
0,922 Kg/m	6000 mm

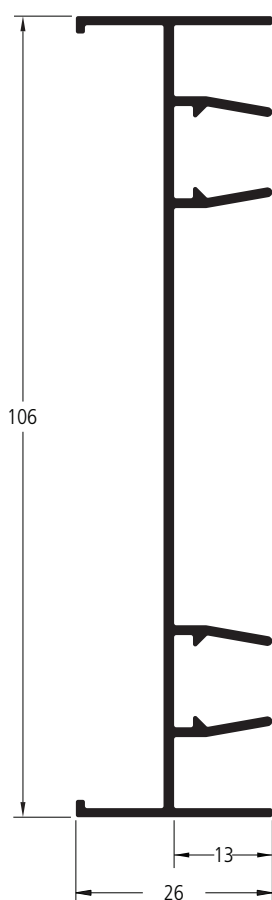

BS-509E	6060-T5
0,767 Kg/m	6000 mm

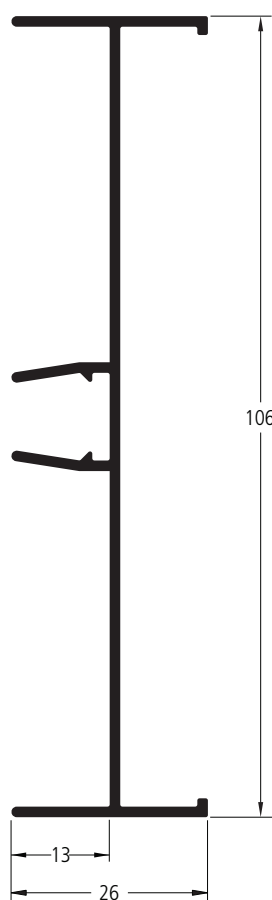

BS-510E	6060-T5
0,671 Kg/m	6000 mm

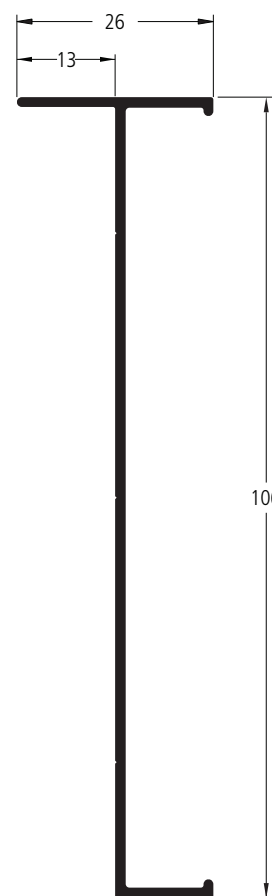

BS-533E	6060-T5
0,559 Kg/m	6000 mm

As informações contidas neste catálogo são de propriedade da BELMETAL e estão sujeitas a alterações sem aviso prévio. Verifique o site www.belmetal.com.br para obter a versão mais atualizada.

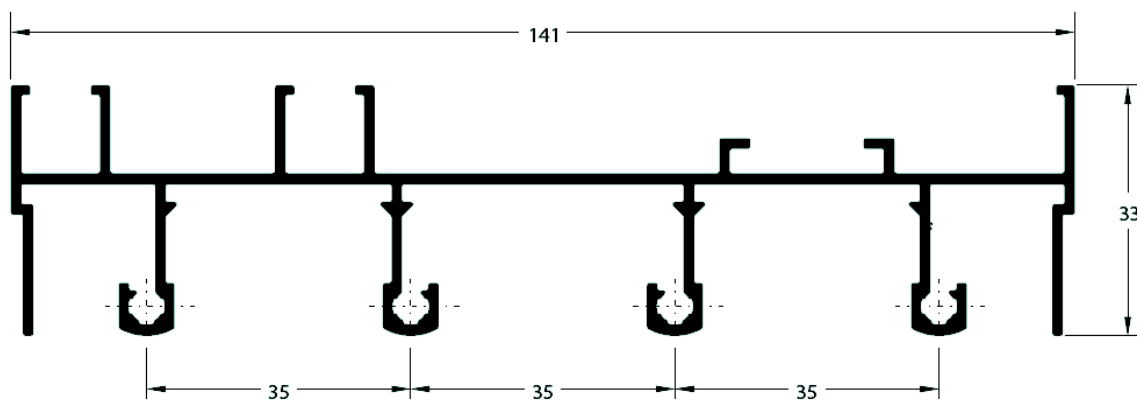

SI-2576E	6060-T5
1,585 Kg/m	6000 mm

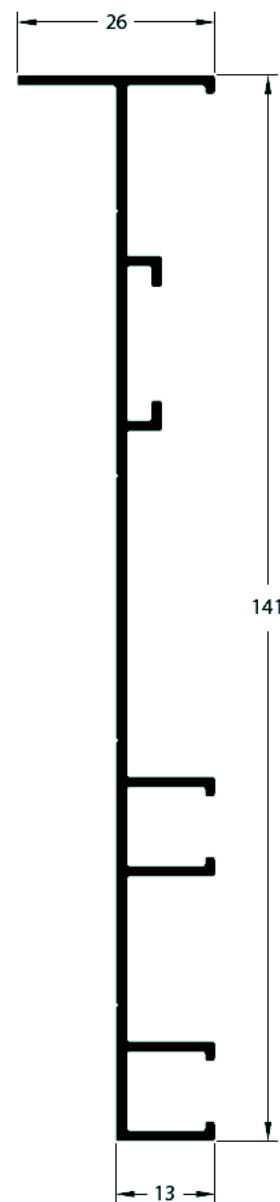

SI-2577E	6060-T5
0,917 Kg/m	6000 mm

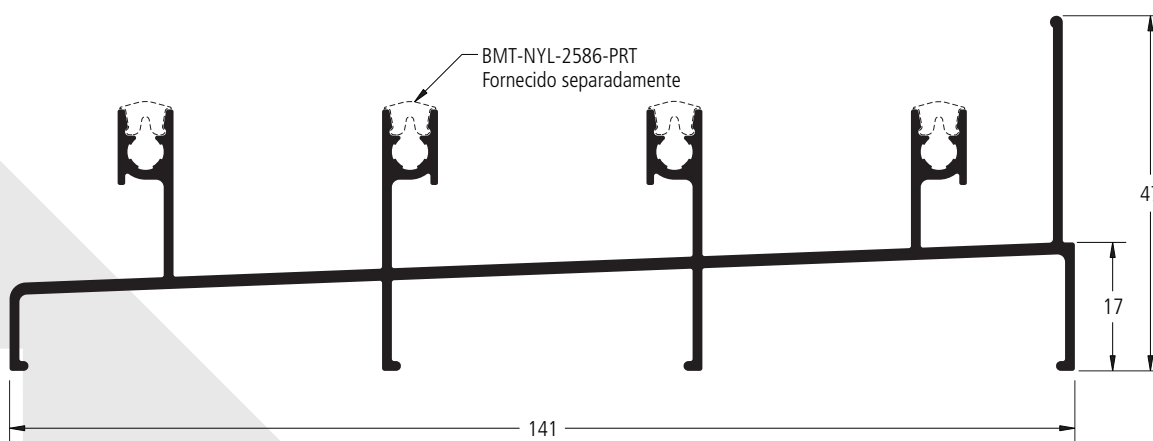

SI-2569	6060-T5
1,445 Kg/m	6000 mm

As informações contidas neste catálogo são de propriedade da BELMETAL e estão sujeitas a alterações sem aviso prévio. Verifique o site www.belmetal.com.br para obter a versão mais atualizada.

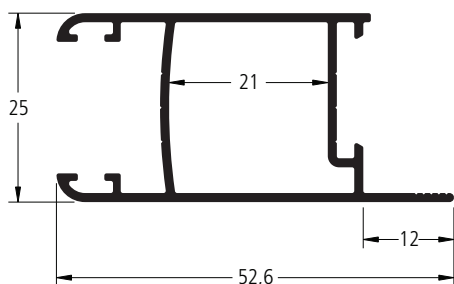

SI-2527 6060-T5
0,512 Kg/m 6000 mm

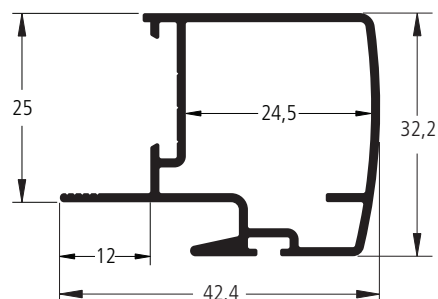

SI-2531 6060-T5
0,505 Kg/m 6000 mm

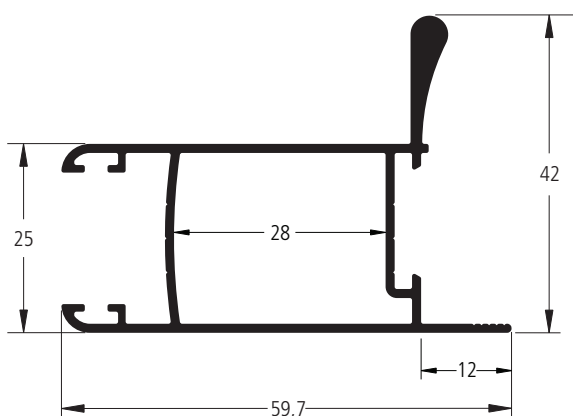

SI-2529 6060-T5
0,697 Kg/m 4600 mm

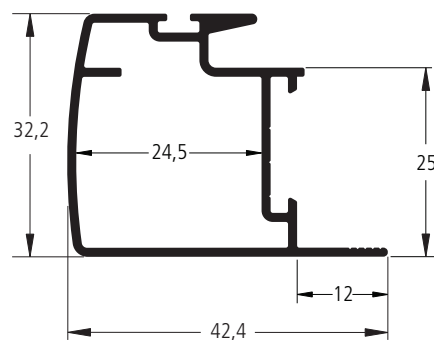

SI-2532 6060-T5
0,505 Kg/m 6000 mm

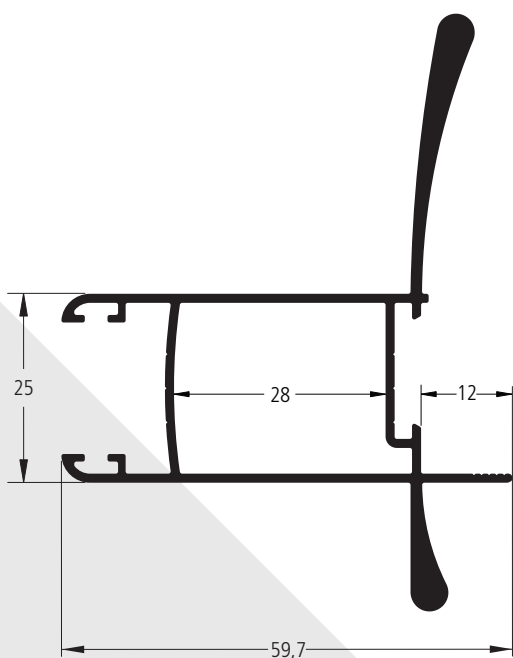

SI-2530 6060-T5
0,975 Kg/m 4600 mm

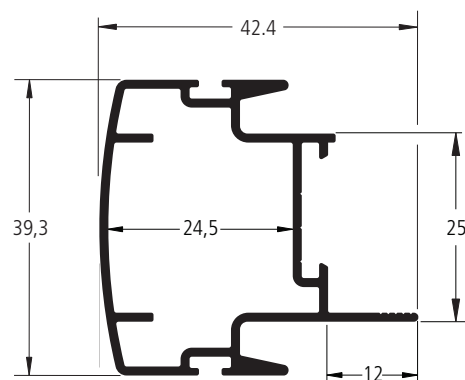

SI-2567 6060-T5
0,612 kg/m 6000 mm

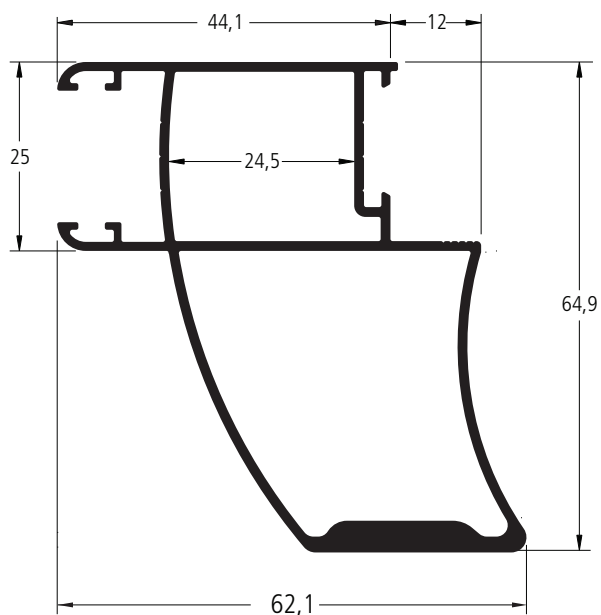

SI-2586	6060-T5
1,131 Kg/m	4600 mm

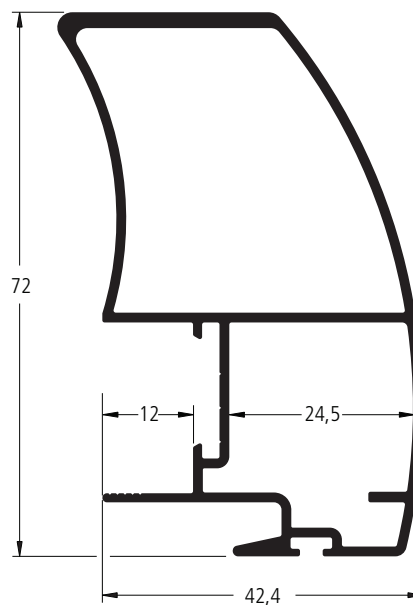

SI-2533	6060-T5
1,037 kg/m	4600 mm

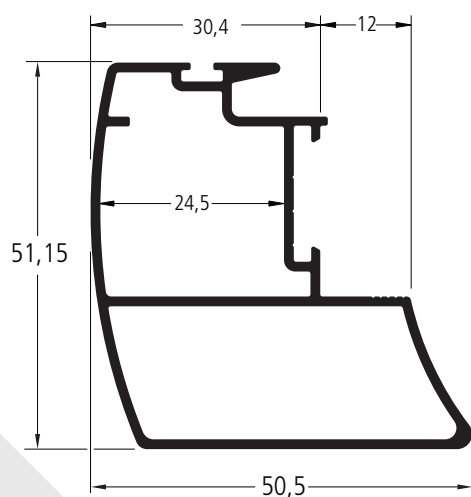

SI-2600	6060-T5
0,827 kg/m	4600 mm

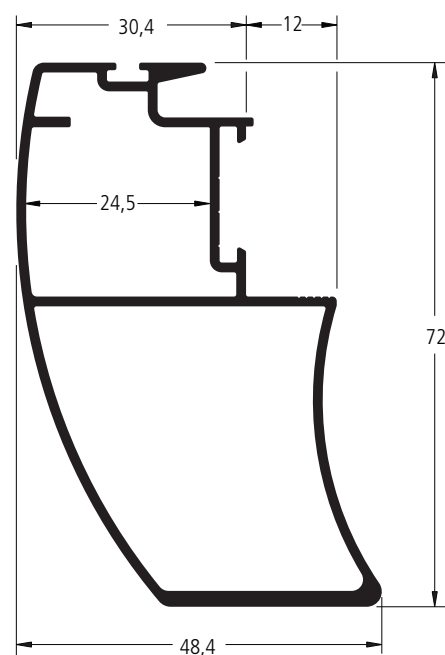

SI-2534	6060-T5
1,001 kg/m	4600 mm

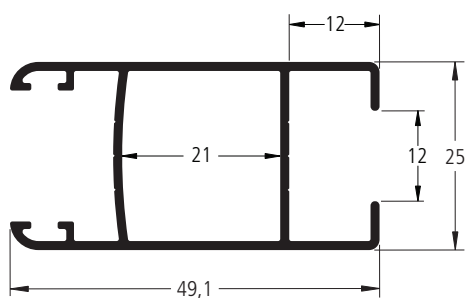

SI-2535	6060-T5
0,535 kg/m	6000 mm

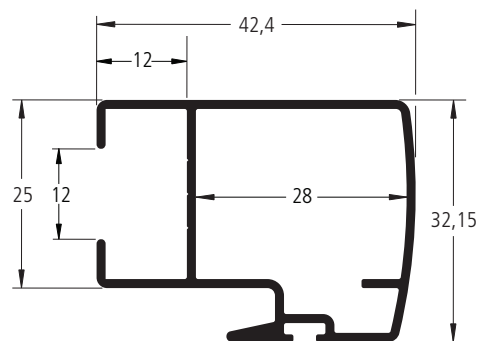

SI-2538	6060-T5
0,551 kg/m	6000 mm

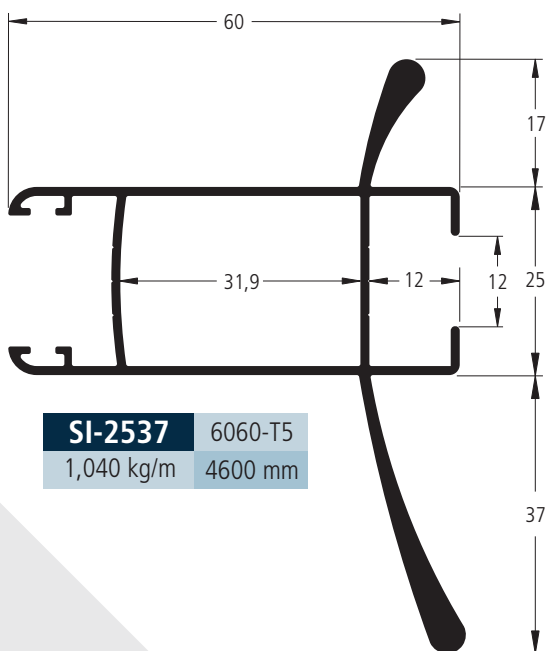

SI-2537	6060-T5
1,040 kg/m	4600 mm

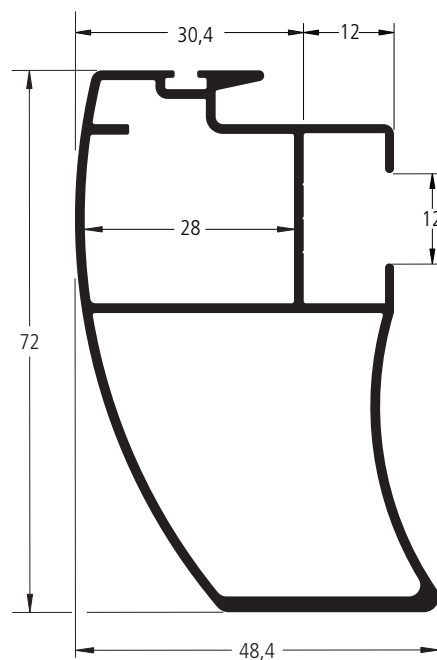

SI-2539	6060-T5
1,046 kg/m	4600 mm

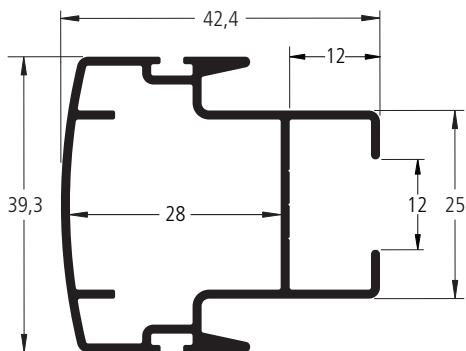

SI-2540 6060-T5
0,656 kg/m 6000 mm

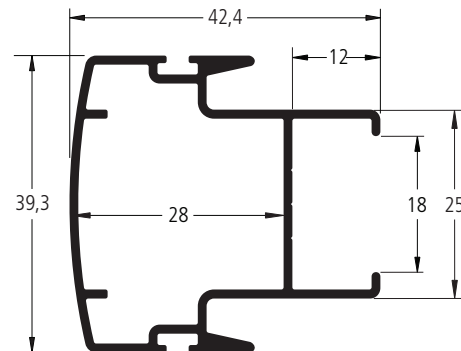

SI-2597 6060-T5
0,624 Kg/m 6000 mm

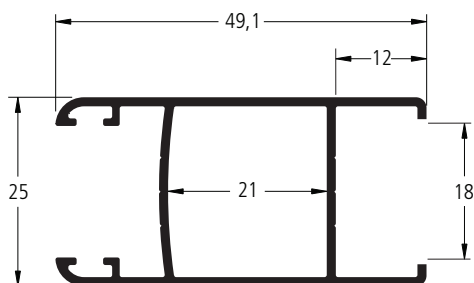

SI-2593 6060-T5
0,518 Kg/m 6000 mm

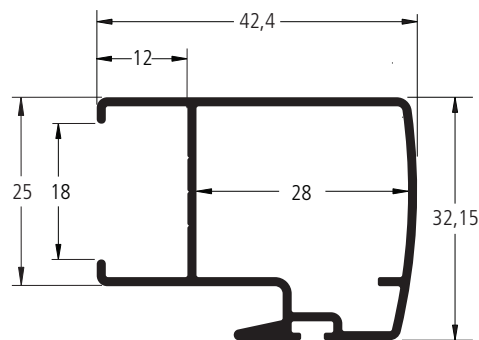

SI-2598 6060-T5
0,525 Kg/m 6000 mm

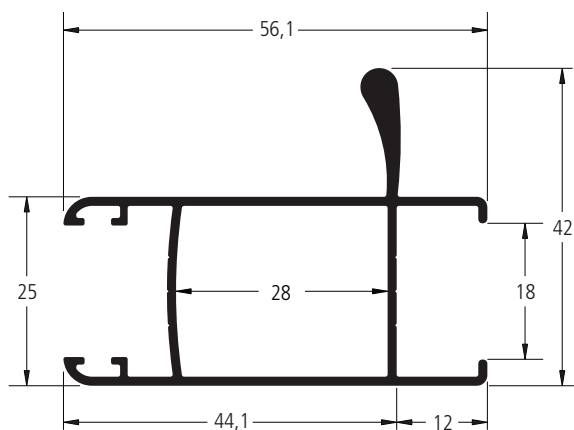

SI-2596 6060-T5
0,698 Kg/m 4600 mm

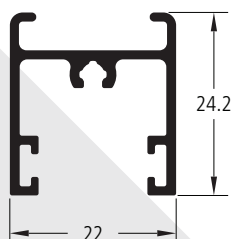

SI-2572 6060-T5
0,328 kg/m 3000 mm

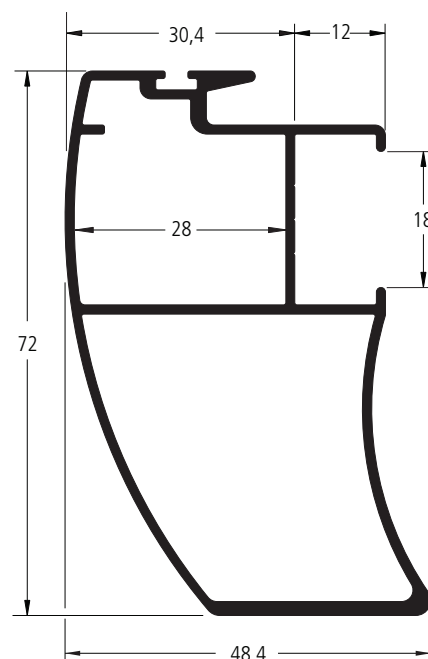

SI-2603 6060-T5
1,021 Kg/m 4600 mm

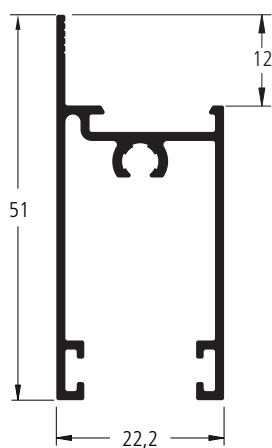

BS-529E 6060-T5
0,542 kg/m 6000 mm

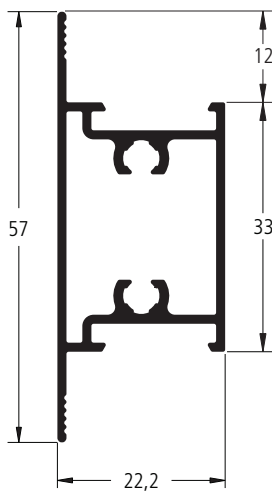

BS-608E 6060-T5
0,574 kg/m 6000 mm

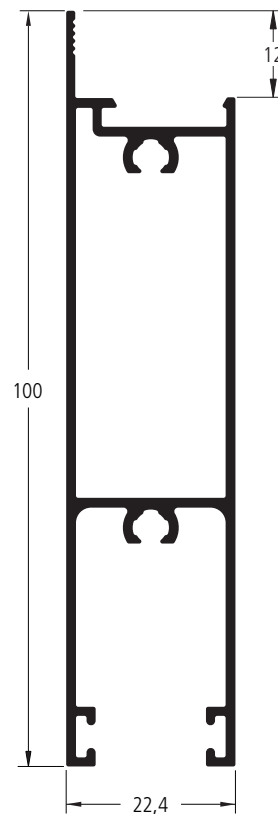

BS-609E 6060-T5
0,926 kg/m 6000 mm

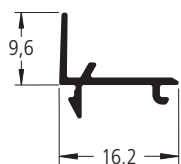

SI-2642 6060-T5
0,108 kg/m 6000 mm

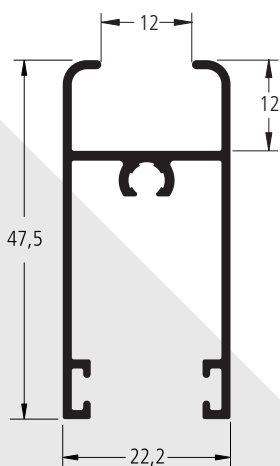

BS-581E 6060-T5
0,496 Kg/m 6000 mm

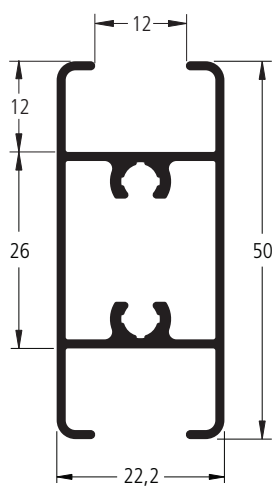

BS-631E 6060-T5
0,586 Kg/m 6000 mm

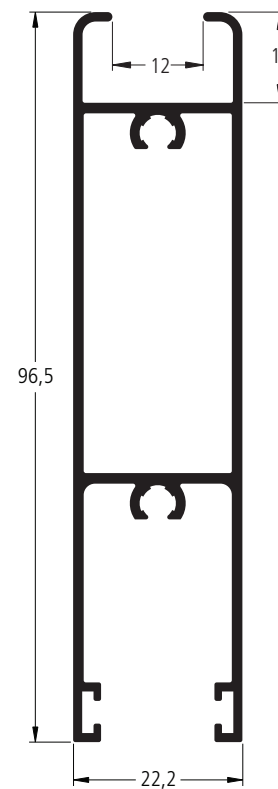

BS-632E 6060-T5
0,945 Kg/m 6000 mm

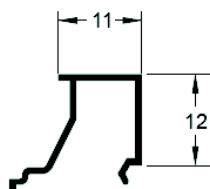

BS-731E	6060-T5
0,110 kg/m	6000 mm

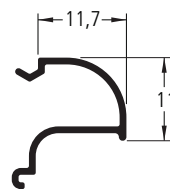

BS-593	6060-T5
0,107 kg/m	6000 mm

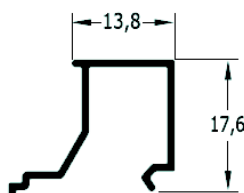

BS-732E	6060-T5
0,156 Kg/m	6000 mm

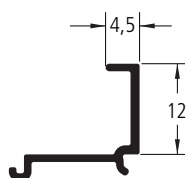

SI-2605	6060-T5
0,107 kg/m	6000 mm

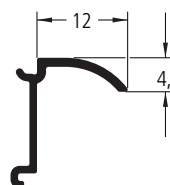

SI-2604	6060-T5
0,101 kg/m	6000 mm

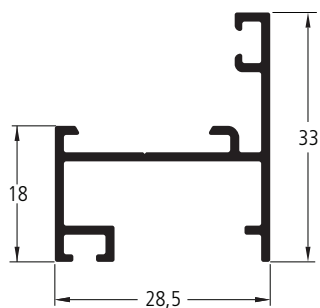

SI-2620	6060-T5
0,351 Kg/m	6000 mm

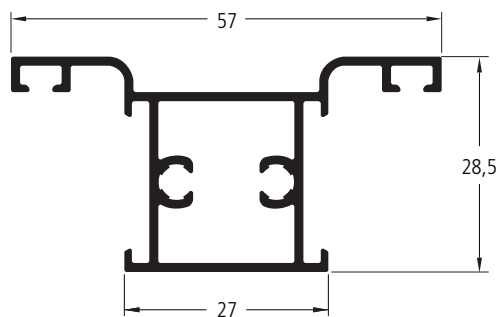

BS-737	6060-T5
0,596 Kg/m	6000 mm

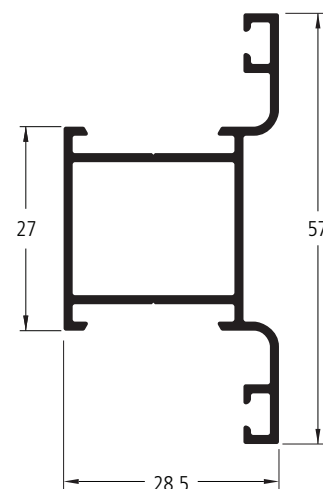

BS-738	6060-T5
0,517 Kg/m	6000 mm

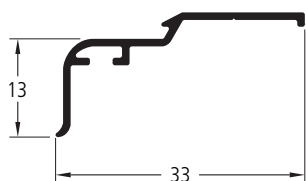

BS-739A	6060-T5
0,144 Kg/m	6000 mm

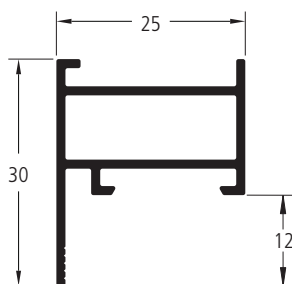

BS-751	6060-T5
0,332 kg/m	6000 mm

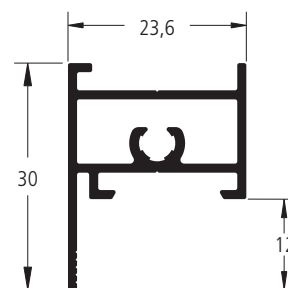

BS-752A	6060-T5
0,370 Kg/m	6000 mm

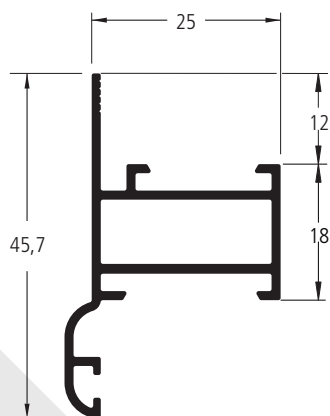

SI-2618	6060-T5
0,431 kg/m	6000 mm

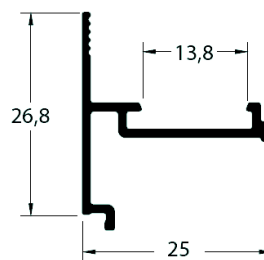

BS-629E	6060-T5
0,214 kg/m	6000 mm

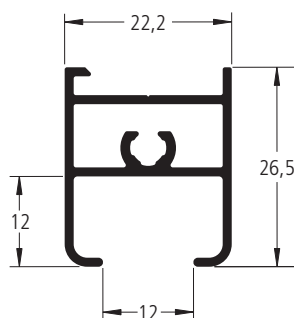

BS-779	6060-T5
0,370 kg/m	6000 mm

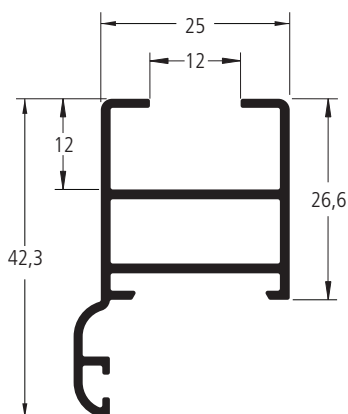

SI-2619	6060-T5
0,474 Kg/m	6000 mm

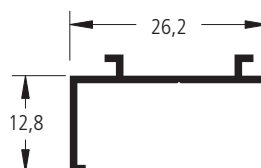

BS-755	6060-T5
0,127 Kg/m	6000 mm

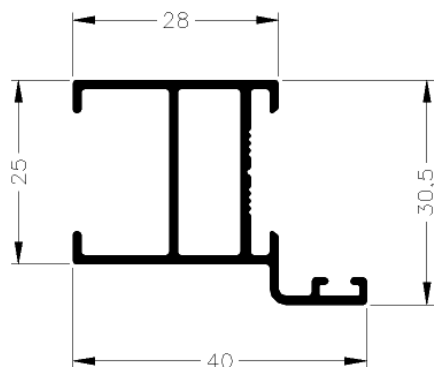

SI-2613E	6060-T5
0,453 Kg/m	6000 mm

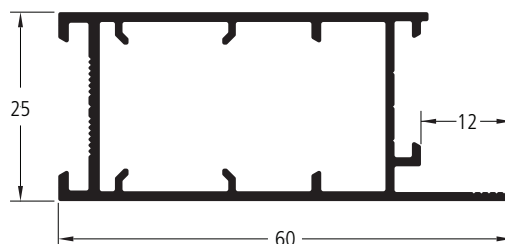

SI-2615	6060-T5
0,635 Kg/m	6000 mm

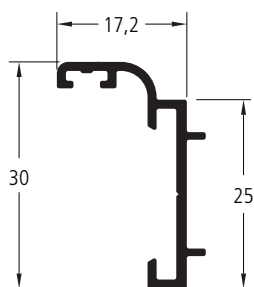

SI-2624	6060-T5
0,220 Kg/m	6000 mm

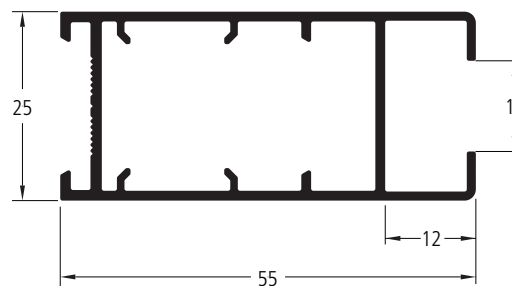

SI-2616	6060-T5
0,653 Kg/m	6000 mm

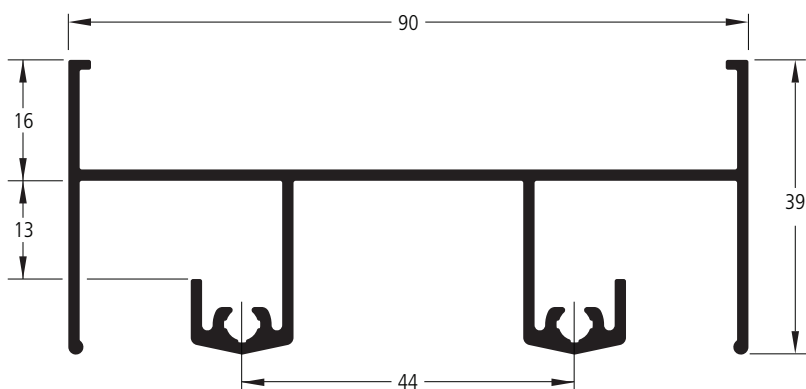

SI-3501S 6060-T5
1,123 kg/m 6000 mm

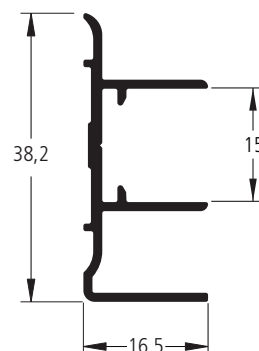

SI-3724 6060-T5
0,309 kg/m 6000 mm

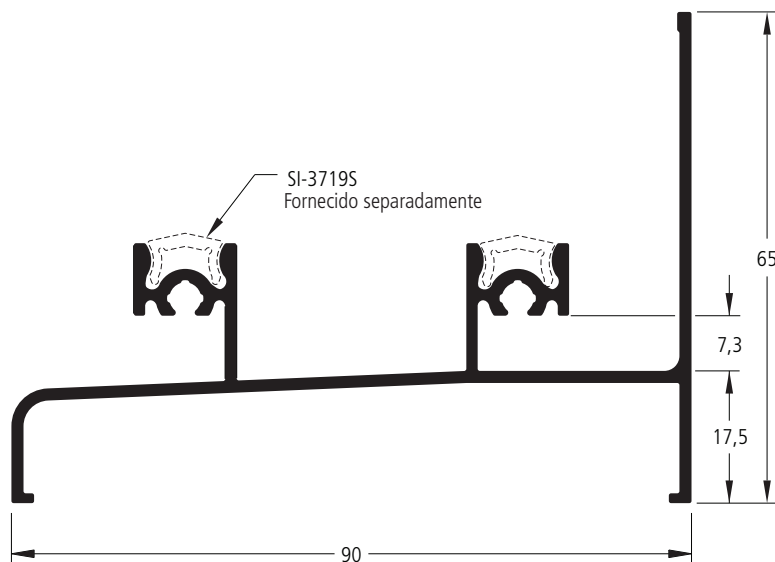

SI-3591S 6060-T5
1,150 kg/m 6000 mm

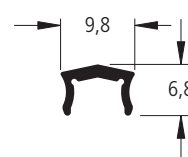

SI-3719S 6060-T5
0,066 kg/m 6000 mm

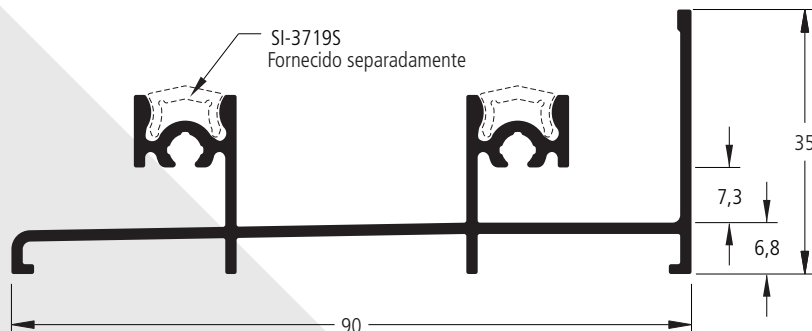

SI-3564S 6060-T5
0,986 kg/m 6000 mm

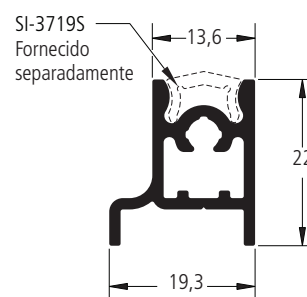

SI-3563S 6060-T5
0,352 kg/m 6000 mm

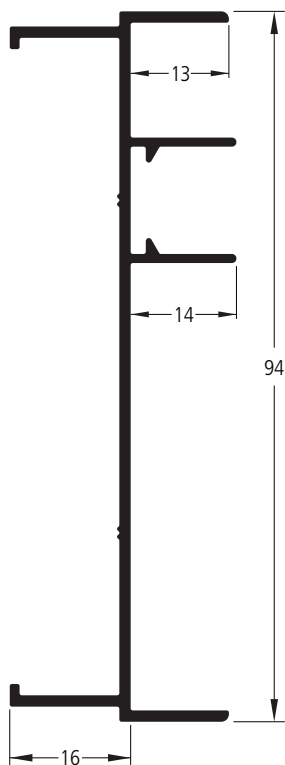

SI-3503S	6060-T5
0,721 kg/m	6000 mm

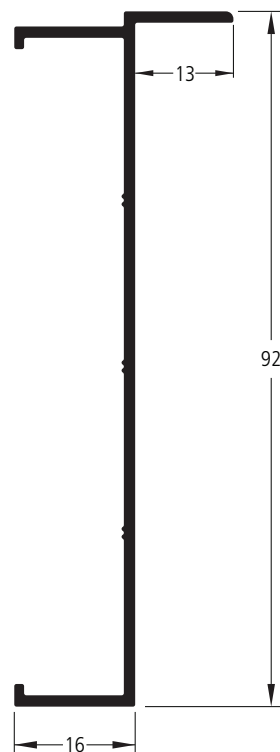

SI-3525S	6060-T5
0,557 kg/m	6000 mm

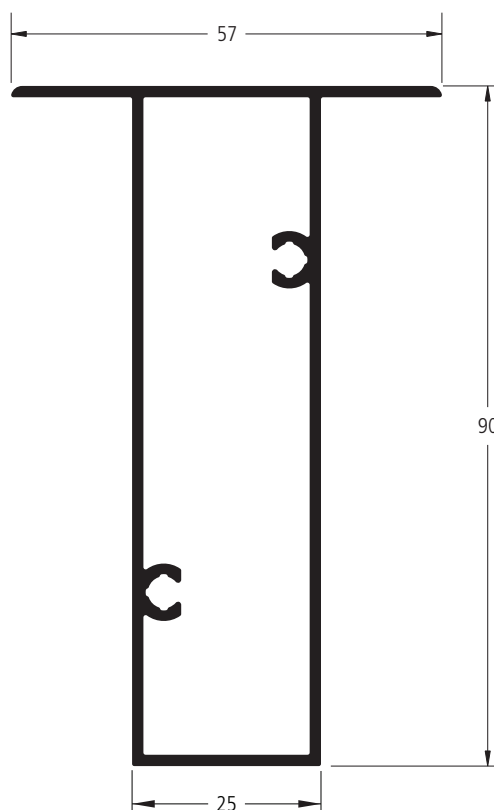

SI-3520	6060-T5
1,131 kg/m	6000 mm

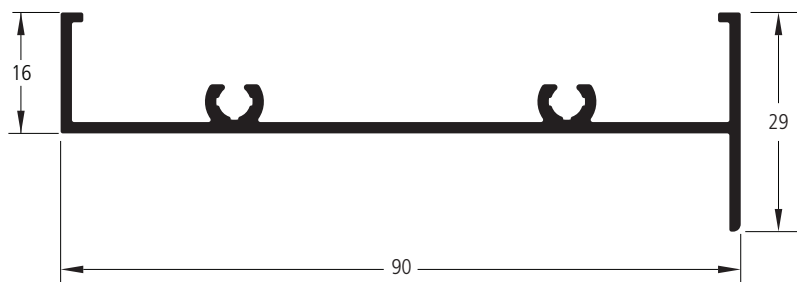

SI-3526S 6060-T5
0,657 kg/m 6000 mm

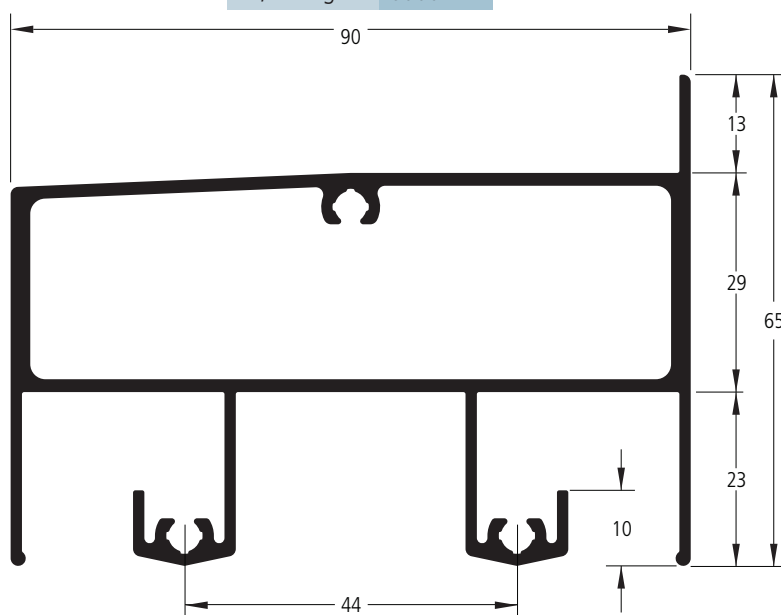

SI-3523S 6060-T5
1,924 kg/m 6000 mm

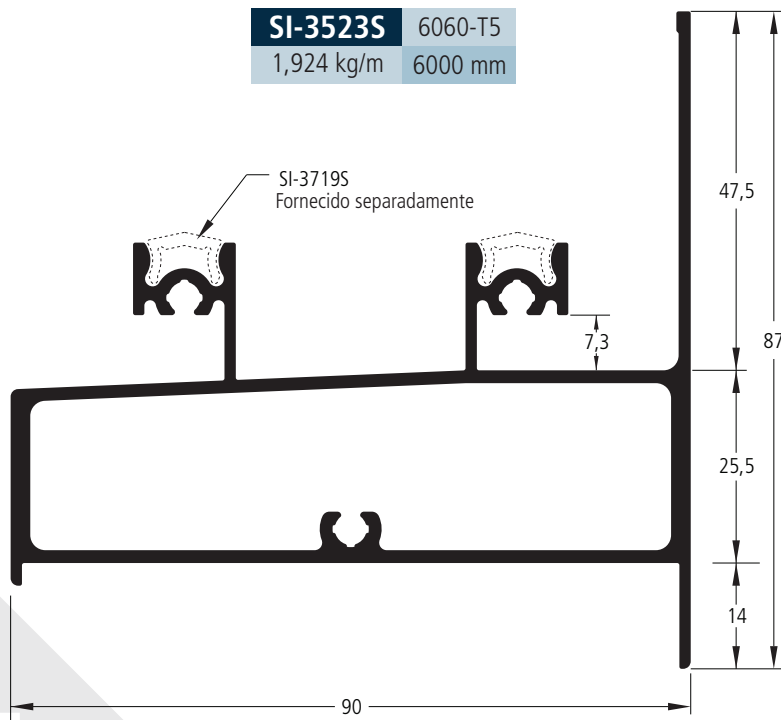

SI-3592S 6060-T5
1,895 kg/m 6000 mm

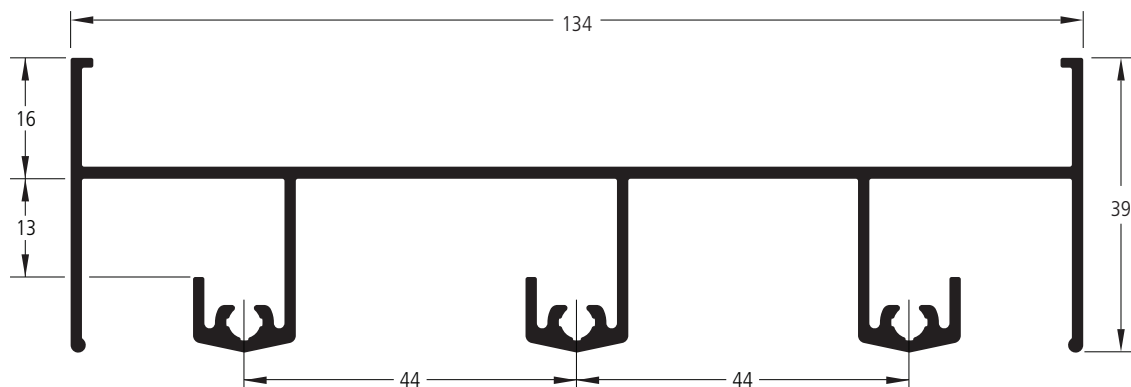

SI-3515S	6060-T5
1,557 kg/m	6000 mm

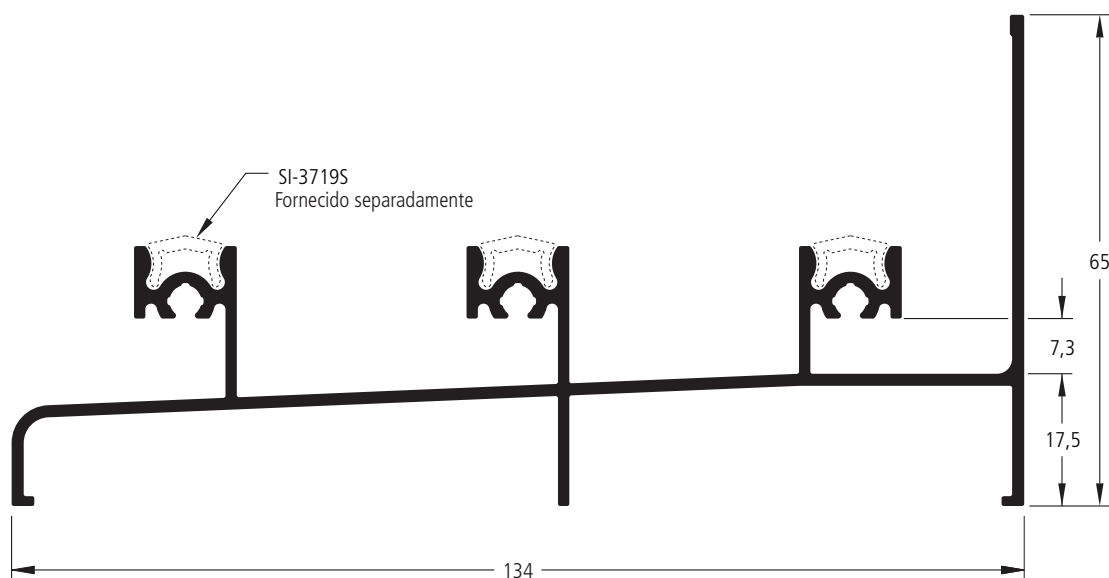

SI-3597S	6060-T5
1,612 kg/m	6000 mm

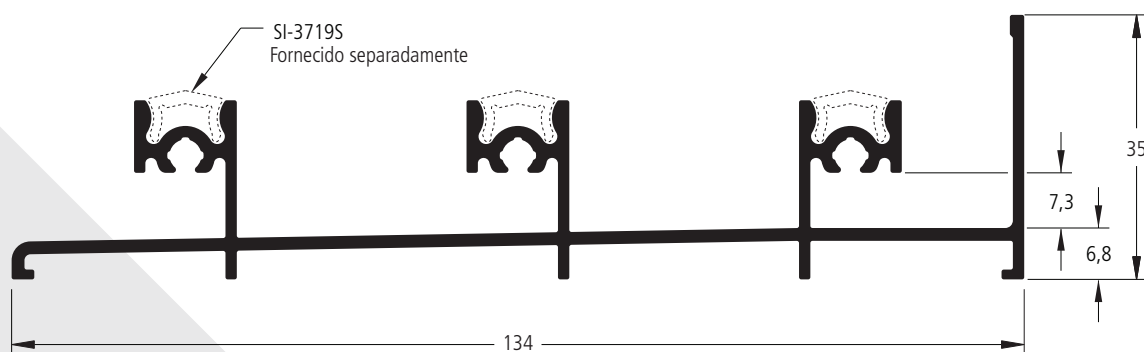

SI-3565S	6060-T5
1,460 kg/m	6000 mm

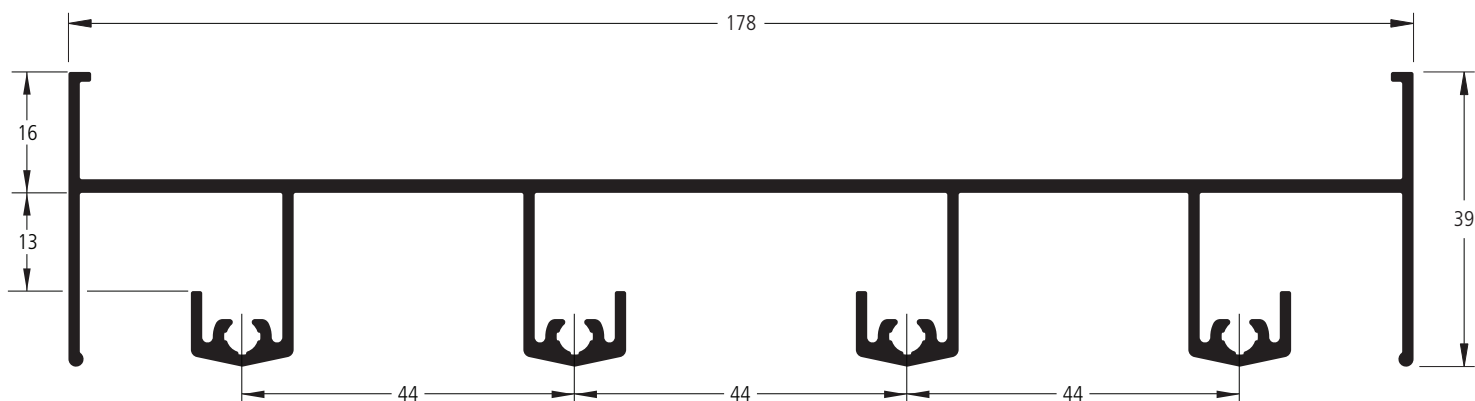

SI-3562S	6060-T5
2,063 kg/m	6000 mm

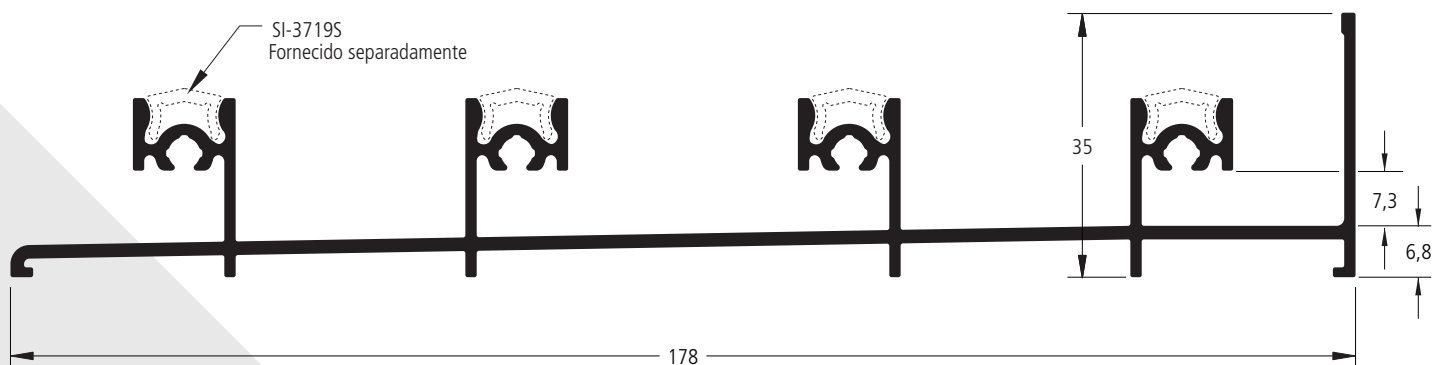

SI-3561S	6060-T5
1,932 kg/m	6000 mm

As informações contidas neste catálogo são de propriedade da BELMETAL e estão sujeitas a alterações sem aviso prévio. Verifique o site www.belmetal.com.br para obter a versão mais atualizada.

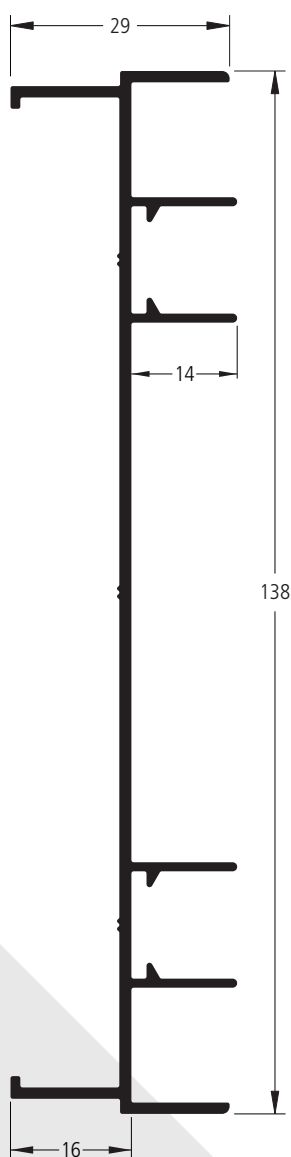

SI-3596S	6060-T5
1,041 kg/m	6000 mm

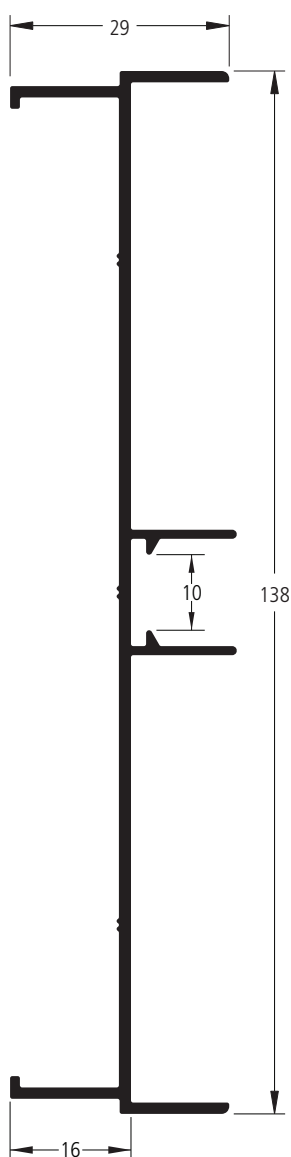

SI-3595S	6060-T5
0,936 kg/m	6000 mm

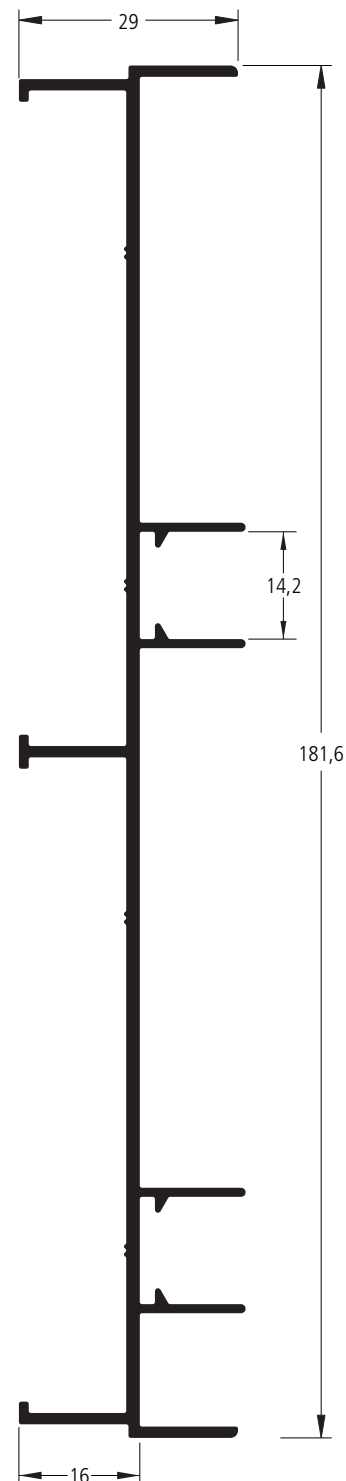

SI-3560S	6060-T5
1,394 kg/m	6000 mm

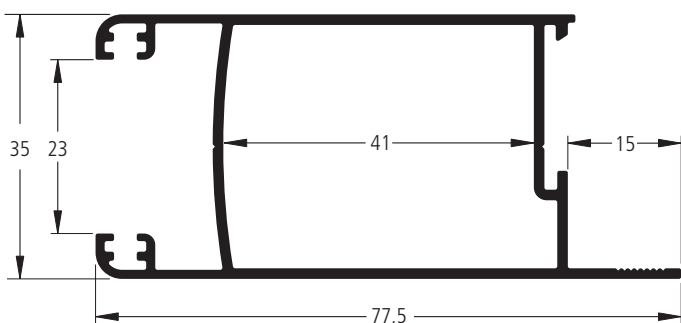

SI-3636S 6060-T5
0,868 kg/m 6000 mm

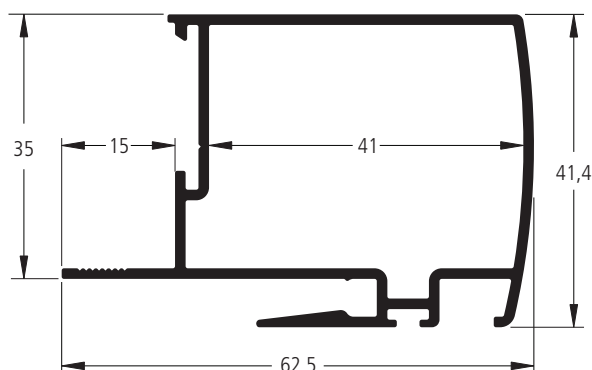

SI-3637S 6060-T5
0,829 kg/m 6000 mm

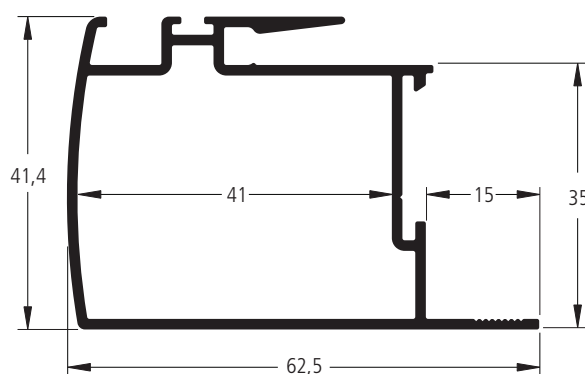

SI-3638S 6060-T5
0,829 kg/m 6000 mm

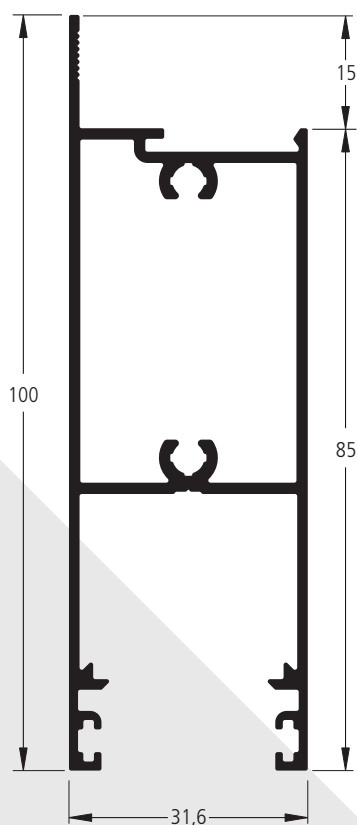

SI-3643S 6060-T5
1,185 kg/m 6000 mm

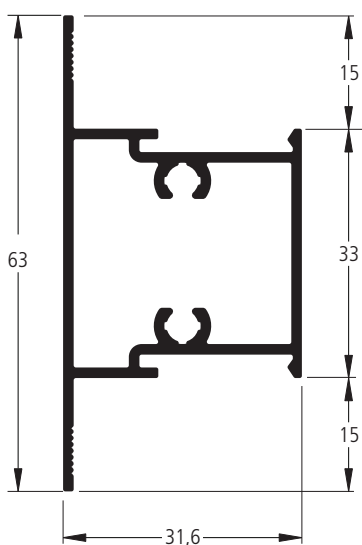

SI-3664S 6060-T5
0,716 kg/m 6000 mm

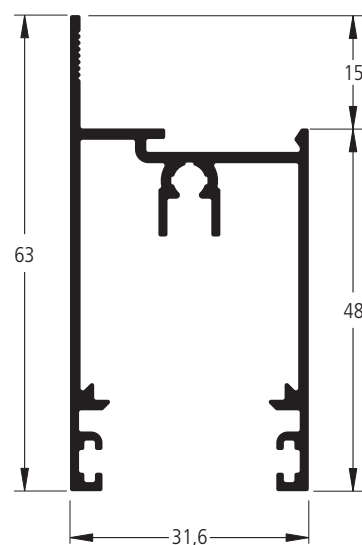

SI-3639S 6060-T5
0,735 kg/m 6000 mm

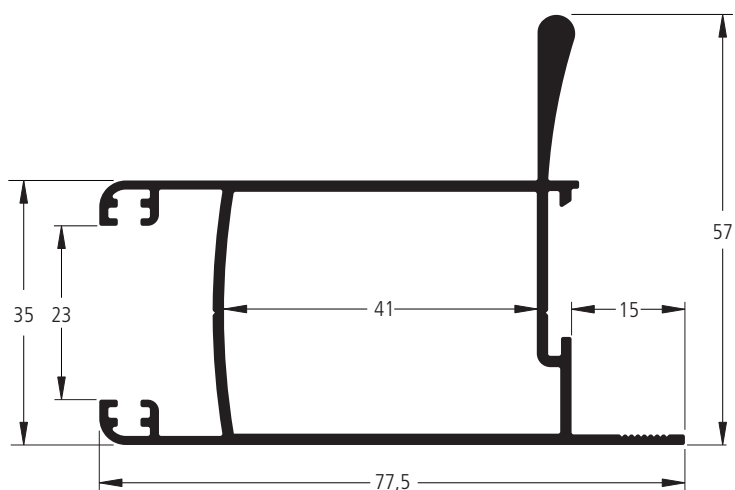

SI-3642S 6060-T5
1,085 kg/m 5000 mm

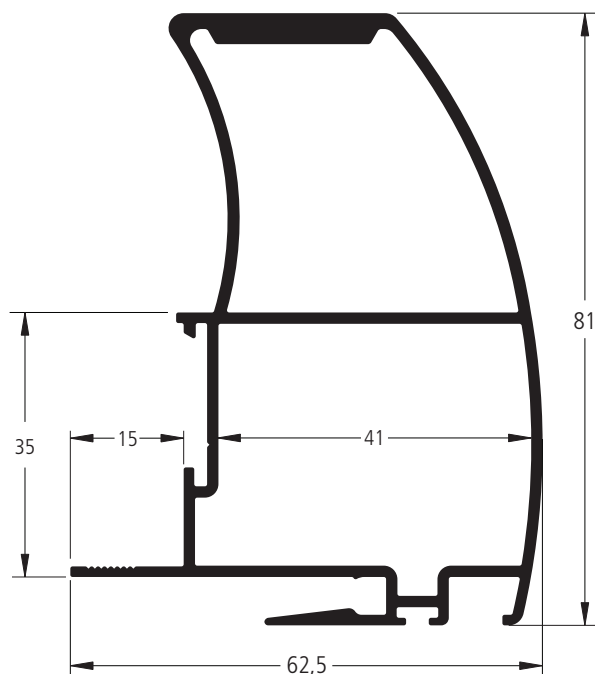

SI-3743 6060-T5
1,546 kg/m 5000 mm

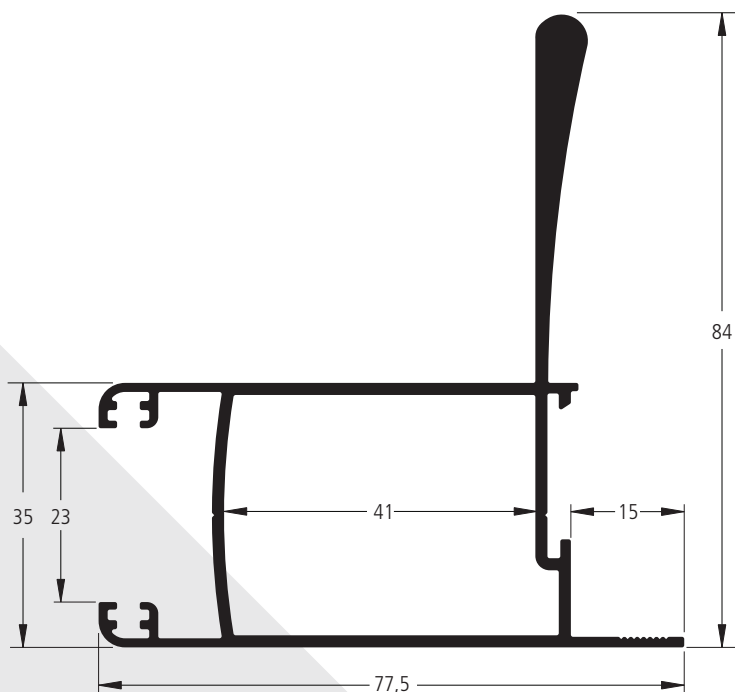

SI-3655S 6060-T5
1,435 kg/m 5000 mm

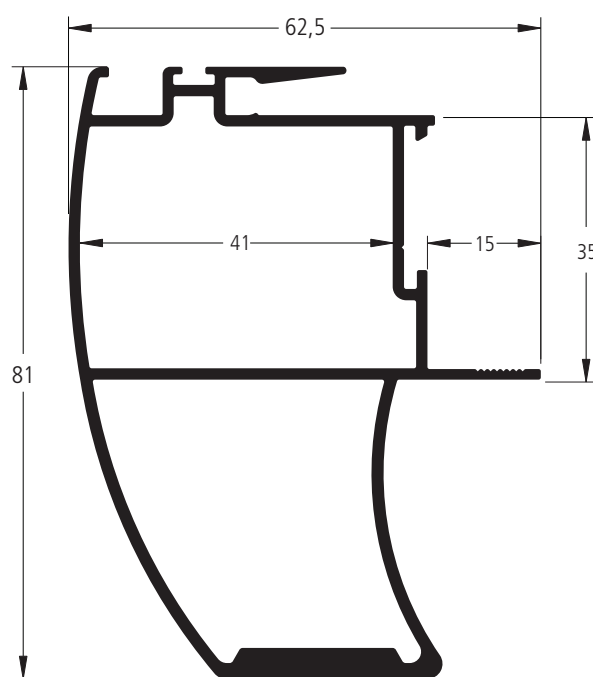

SI-3744 6060-T5
1,546 kg/m 5000 mm

As informações contidas neste catálogo são de propriedade da BELMETAL e estão sujeitas a alterações sem aviso prévio. Verifique o site www.belmetal.com.br para obter a versão mais atualizada.

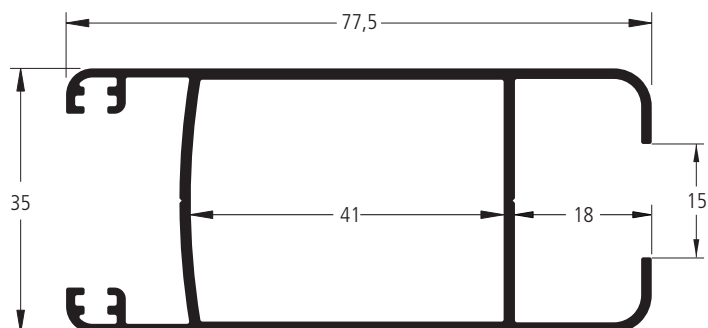

SI-3647S	6060-T5
0,987 kg/m	6000 mm

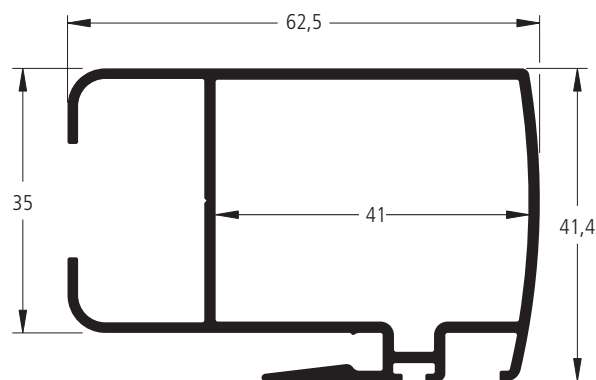

SI-3648S	6060-T5
0,949 kg/m	6000 mm

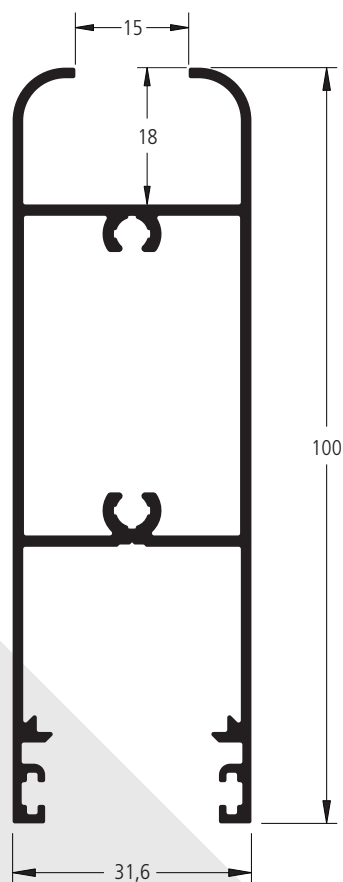

SI-3650S	6060-T5
1,254 kg/m	6000 mm

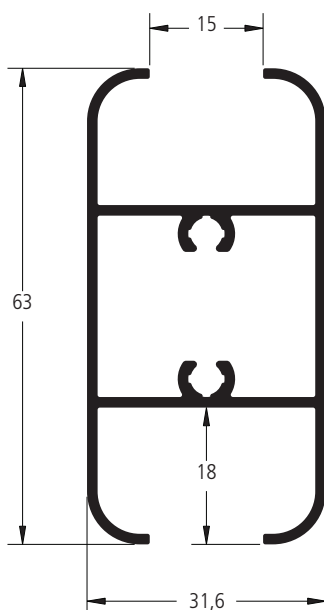

SI-3651S	6060-T5
0,858 kg/m	6000 mm

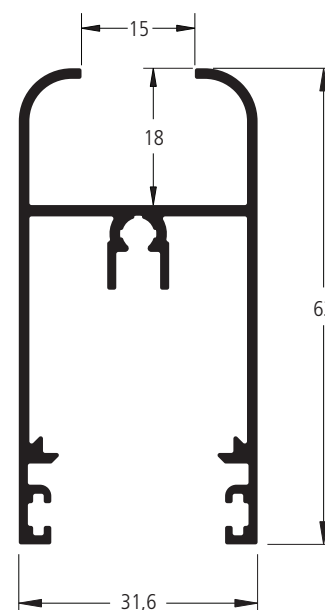

SI-3649S	6060-T5
0,805 kg/m	6000 mm

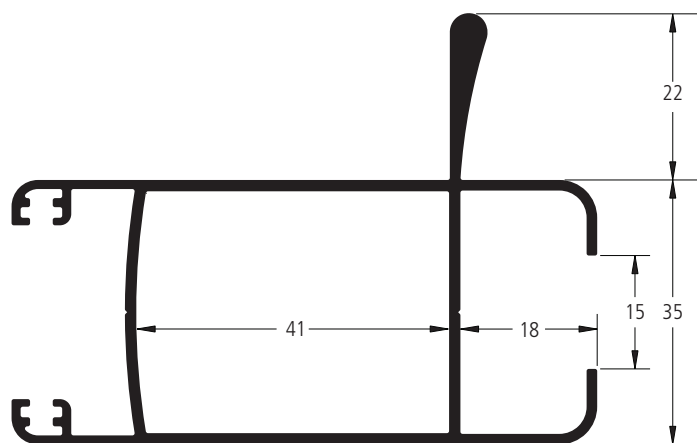

SI-3652S	6060-T5
1,164 kg/m	5000 mm

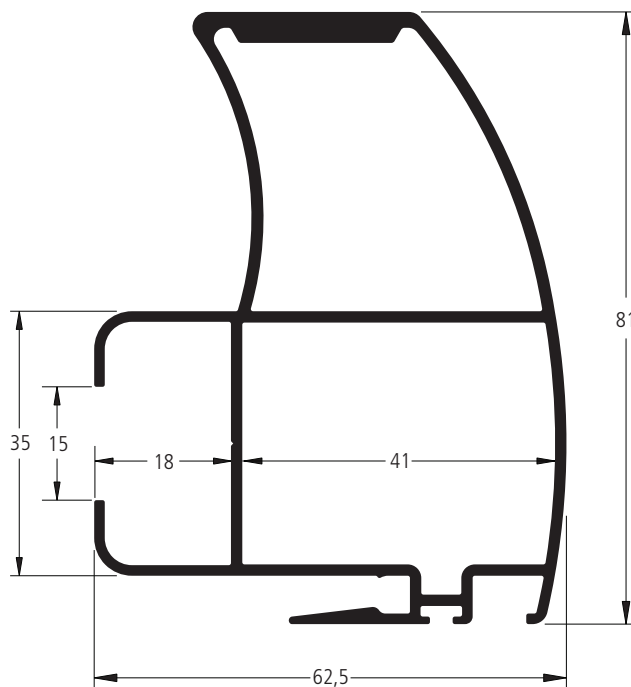

SI-3745	6060-T5
1,649 kg/m	5000 mm

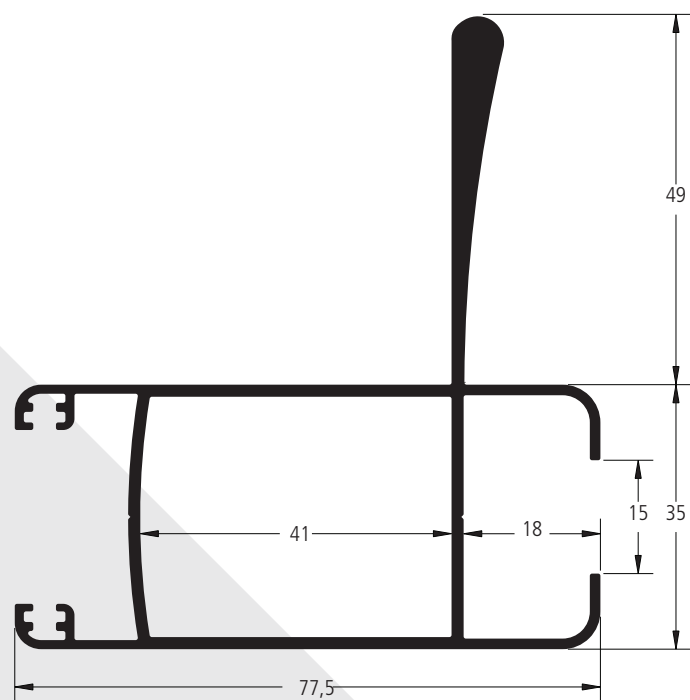

SI-3659S	6060-T5
1,512 kg/m	5000 mm

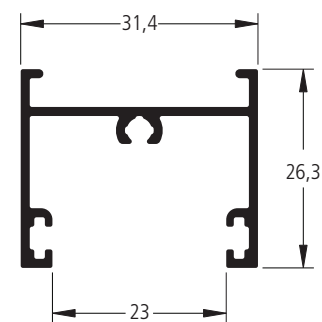

SI-3644S	6060-T5
0,366 kg/m	3000 mm

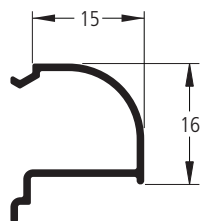

SI-3634 6060-T5
0,141 kg/m 6000 mm

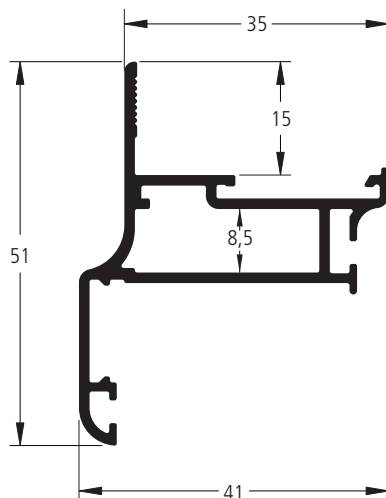

SI-3604S 6060-T5
0,599 kg/m 6000 mm

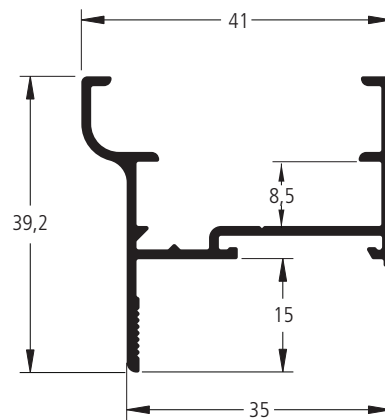

SI-3715S 6060-T5
0,436 kg/m 6000 mm

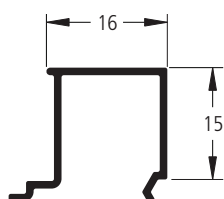

SI-3663 6060-T5
0,152 kg/m 6000 mm

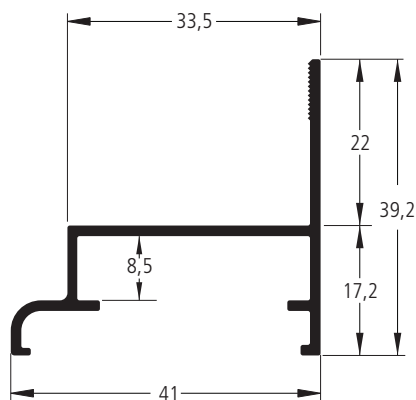

SI-3579S 6060-T5
0,386 Kg/m 6000 mm

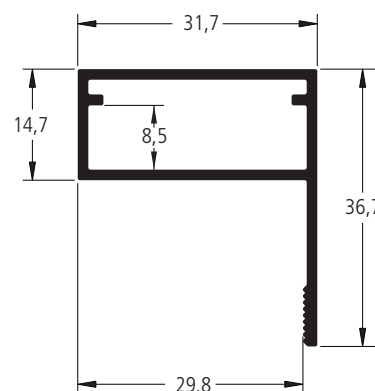

SI-3519S 6060-T5
0,438 kg/m 6000 mm

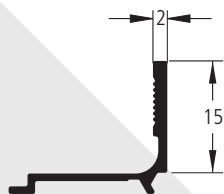

SI-3718 6060-T5
0,132 kg/m 6000 mm

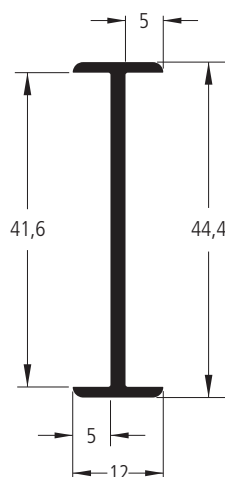

SI-3521S 6060-T5
0,312 kg/m 6000 mm

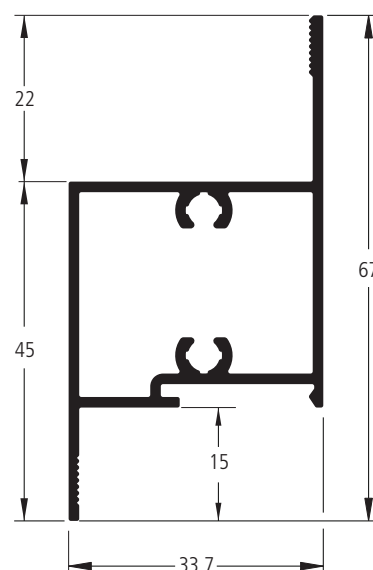

SI-3518S 6060-T5
0,726 kg/m 6000 mm

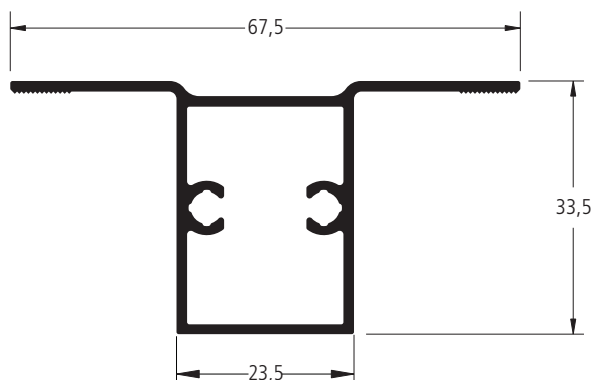

SI-3580	6060-T5
0,667 kg/m	6000 mm

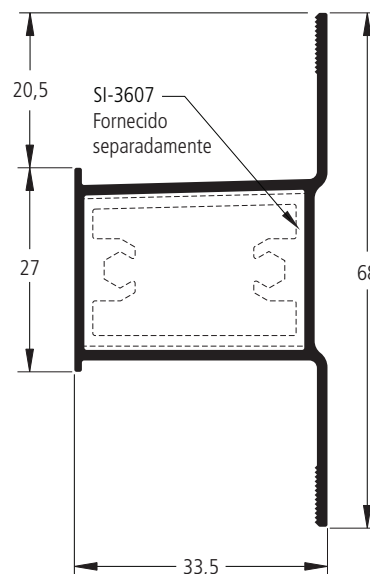

SI-3581	6060-T5
0,586 kg/m	6000 mm

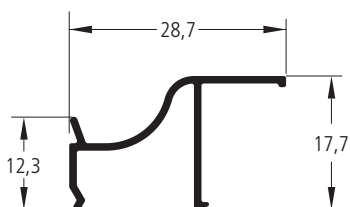

Obs.: Porta palheta horizontal

SI-3733	6060-T5
0,169 kg/m	6000 mm

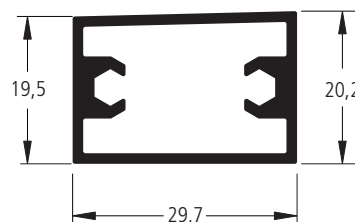

SI-3607	6060-T5
0,493 kg/m	6000 mm

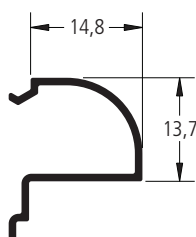

Obs.: Porta palheta vertical

SI-3502S	6060-T5
0,141 kg/m	6000 mm

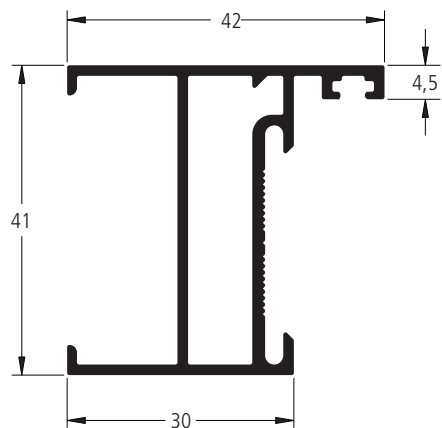

SI-3678S	6060-T5
0,684 kg/m	6000 mm

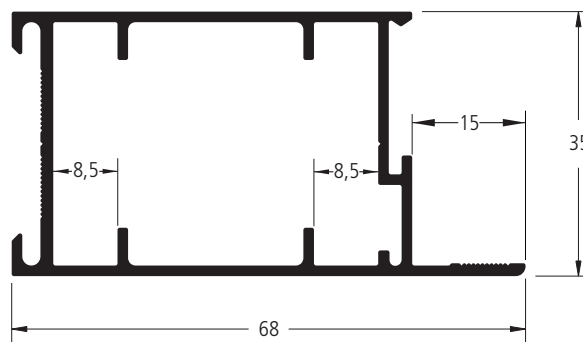

SI-3679	6060-T5
0,873 kg/m	6000 mm

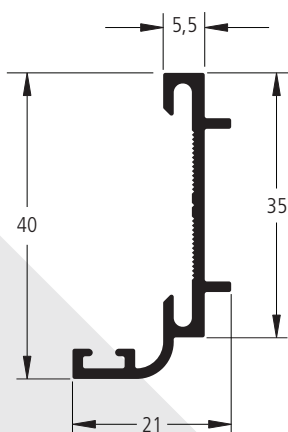

SI-3677	6060-T5
0,331 kg/m	6000 mm

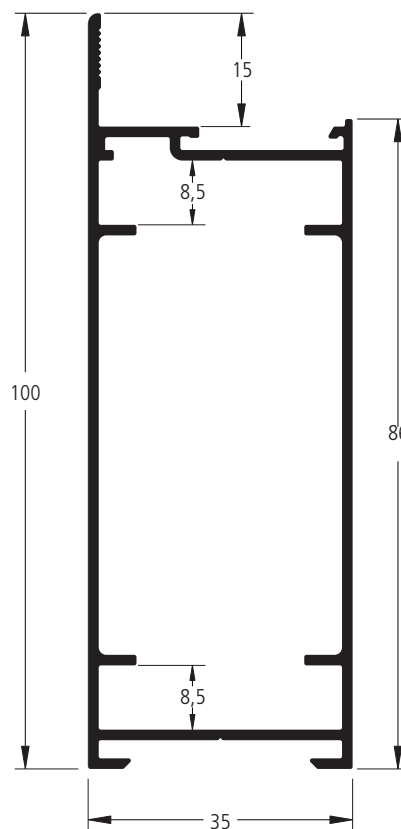

SI-3742	6060-T5
1,095 kg/m	6000 mm

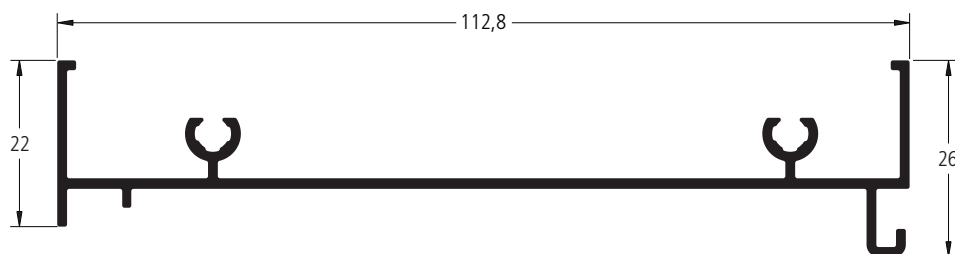

SI-2578	6060-T5
0,748 kg/m	6000 mm

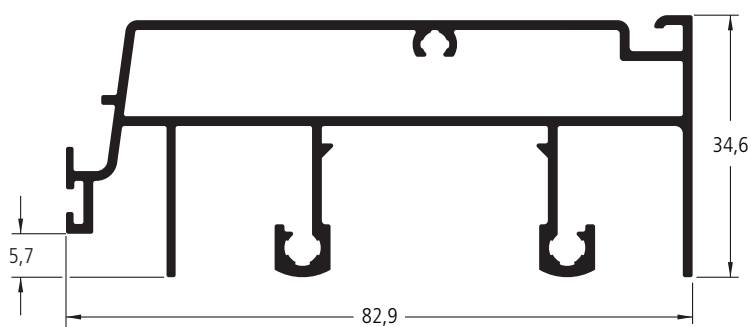

SI-2510	6060-T5
1,168 Kg/m	6000 mm

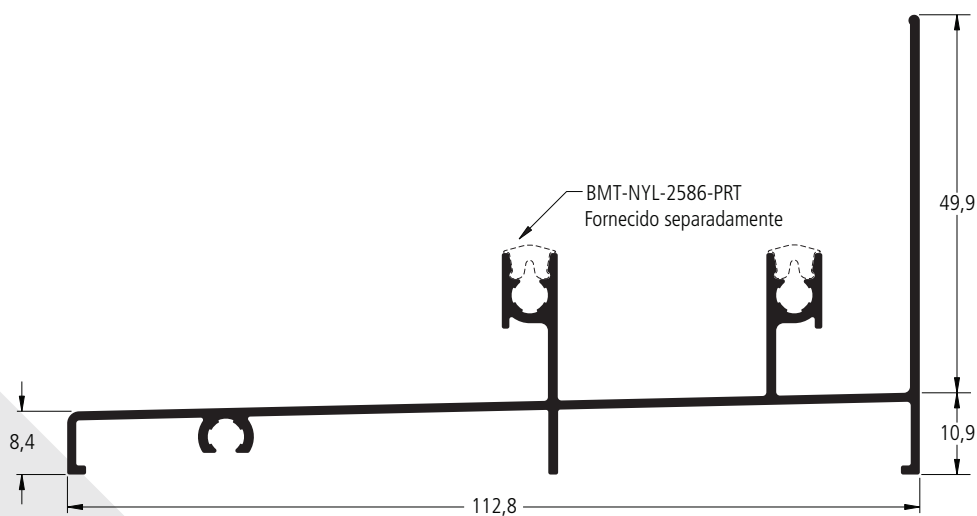

SI-2525A	6060-T5
0,954 Kg/m	6000 mm

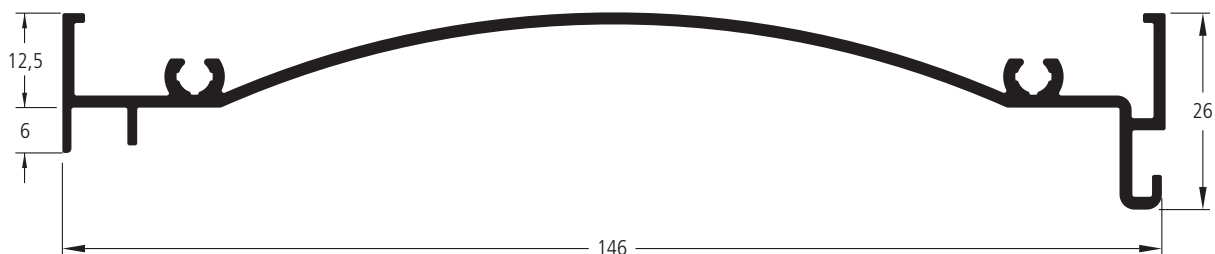

BLI-807S	6060-T5
0,996 kg/m	6000 mm

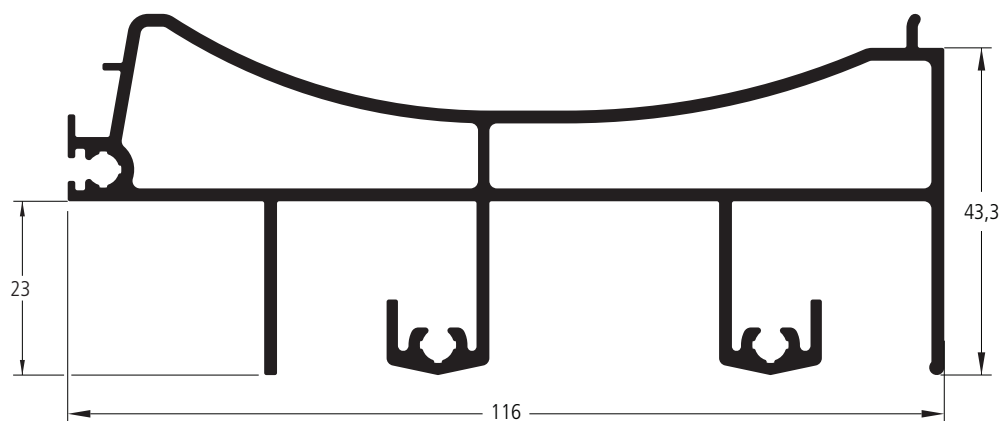

SI-3504S	6060-T5
2,030 kg/m	6000 mm

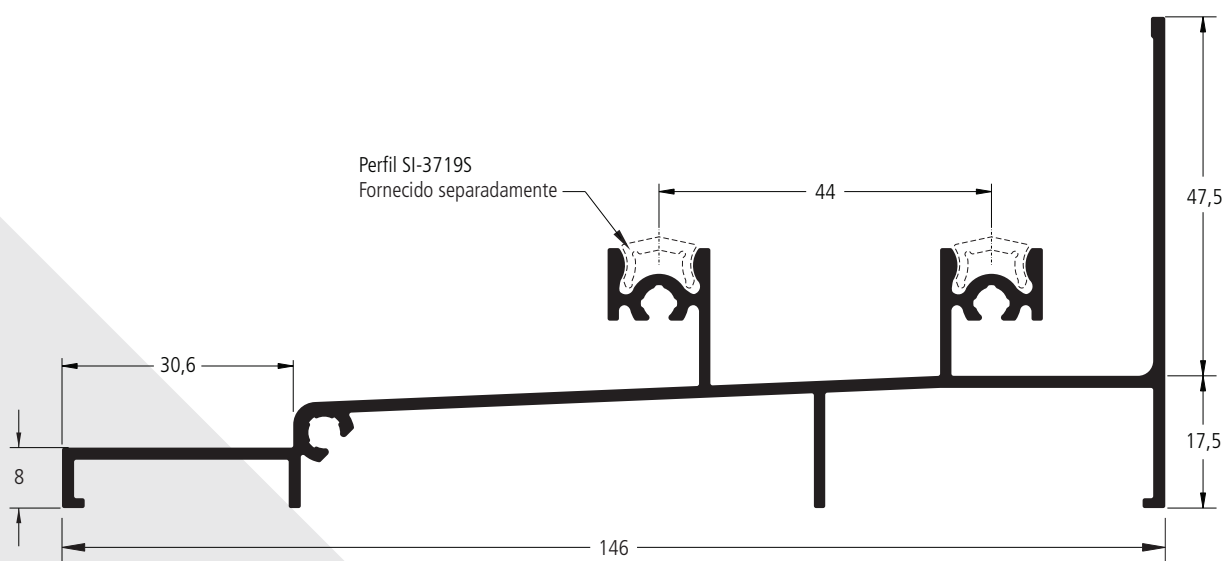

SI-3593S	6060-T5
1,518 kg/m	6000 mm

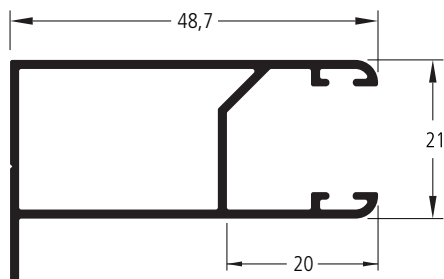

SC-2034	6060-T5
0,514 kg/m	6000 mm

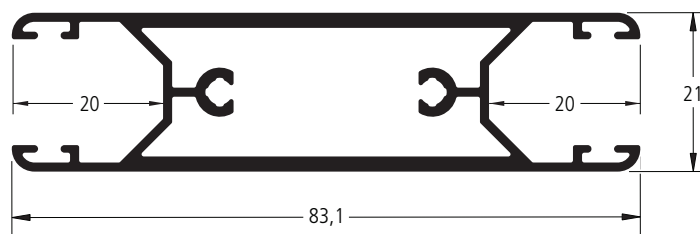

SC-2080	6060-T5
1,141 kg/m	6000 mm

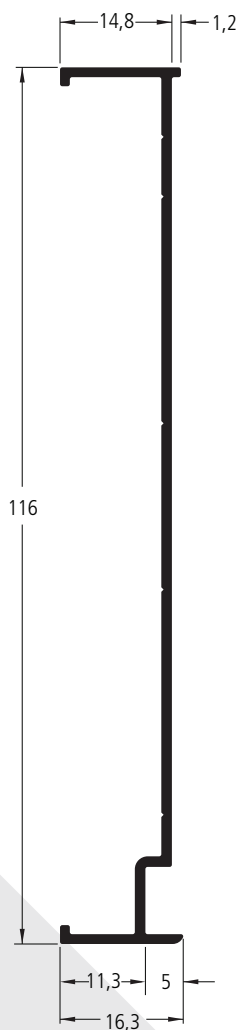

SC-2139	6060-T5
0,561 kg/m	6000 mm

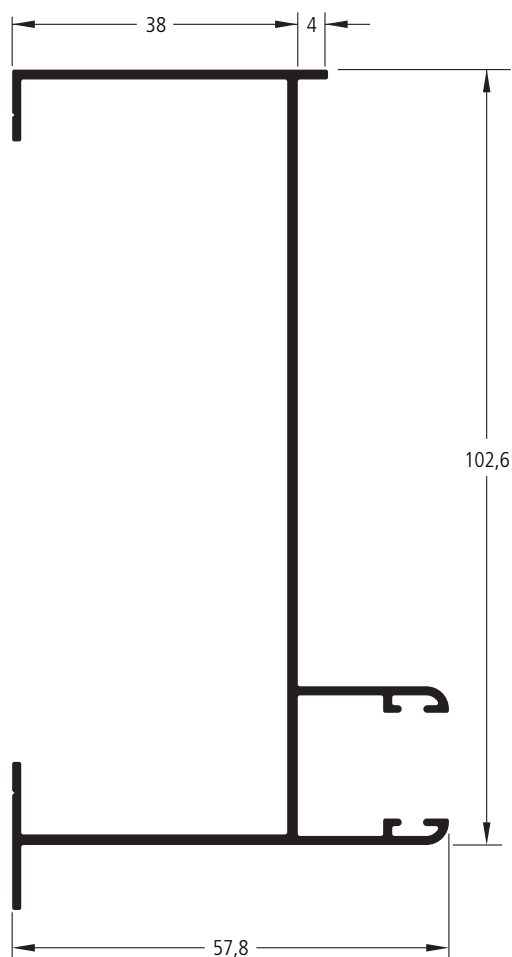

SC-2088	6060-T5
0,942 kg/m	6000 mm



BLI-555	6060-T5
0,311 kg/m	6000 mm

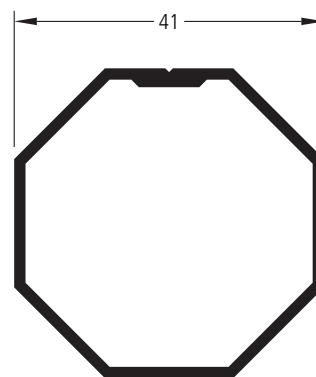

BLI-552E	6060-T5
0,489 kg/m	6000 mm

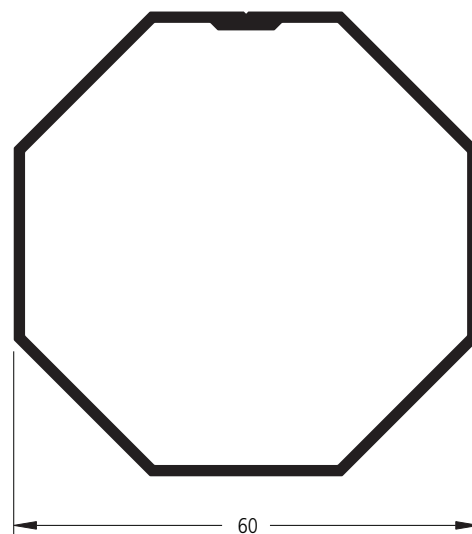

BLI-816E	6060-T5
0,792 kg/m	6000 mm

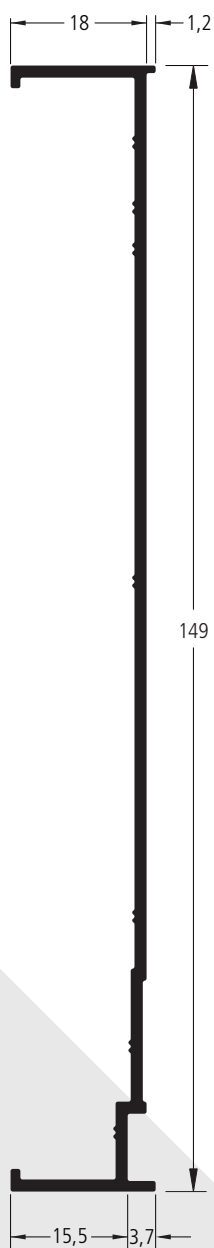

BLI-549S	6060-T5
0,823 kg/m	6000 mm

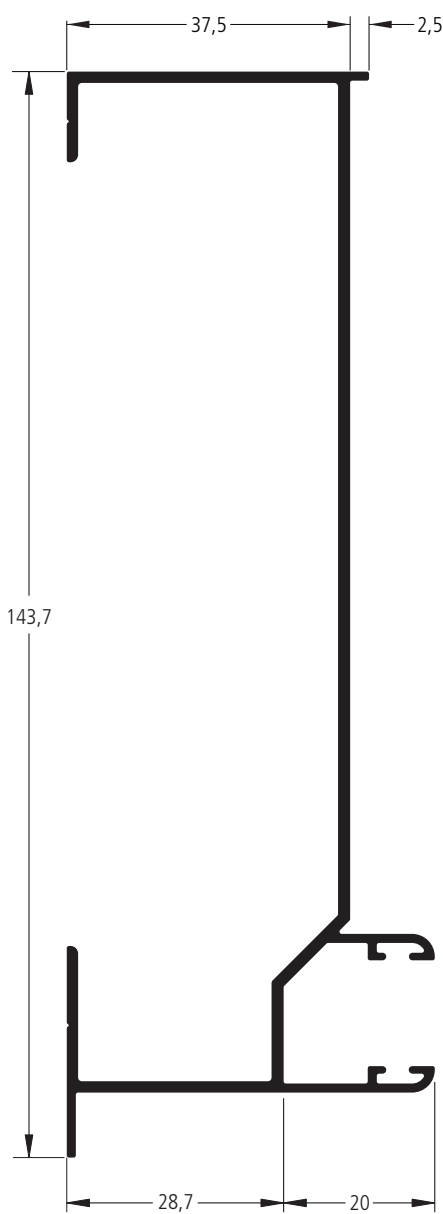

BLI-548S	6060-T5
1,159 kg/m	6000 mm

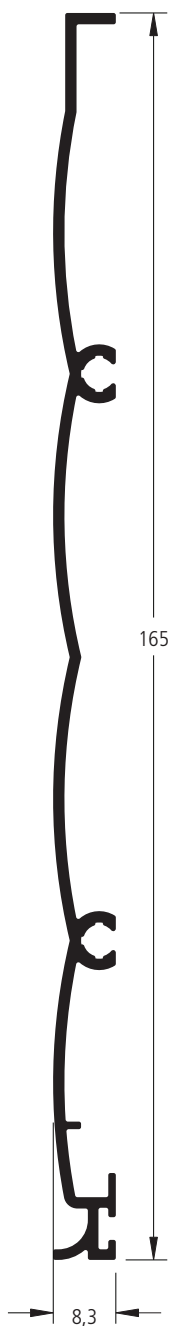

BLI-808S	6060-T5
0,872 kg/m	6000 mm

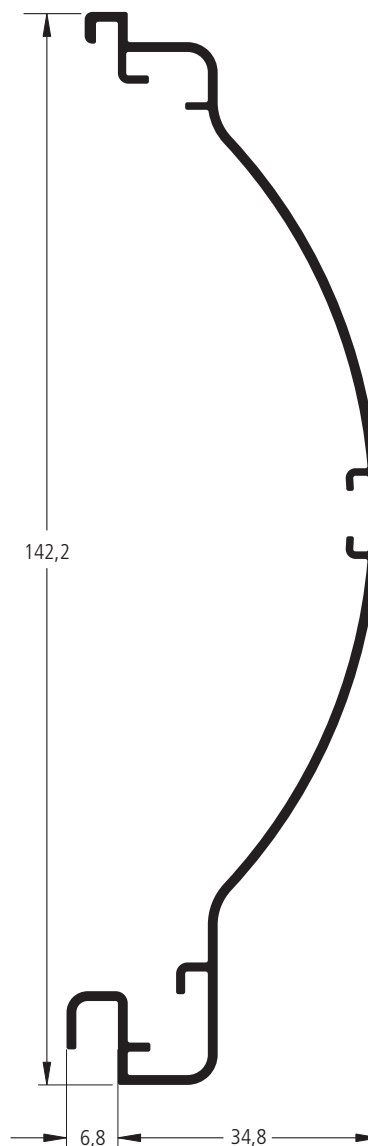

SC-2029	6060-T5
0,883 kg/m	6000 mm

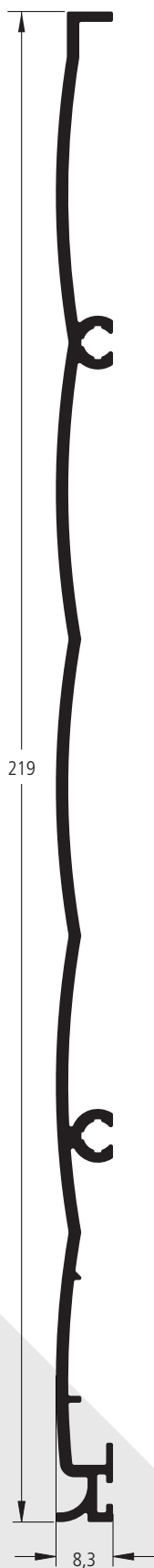

BLI-806S	6060-T5
1,284 kg/m	6000 mm

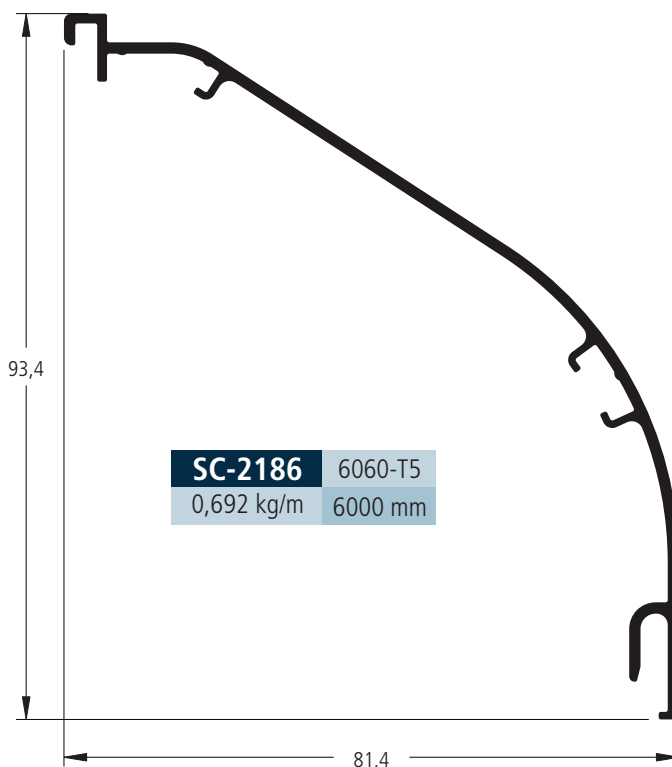

SC-2186	6060-T5
0,692 kg/m	6000 mm

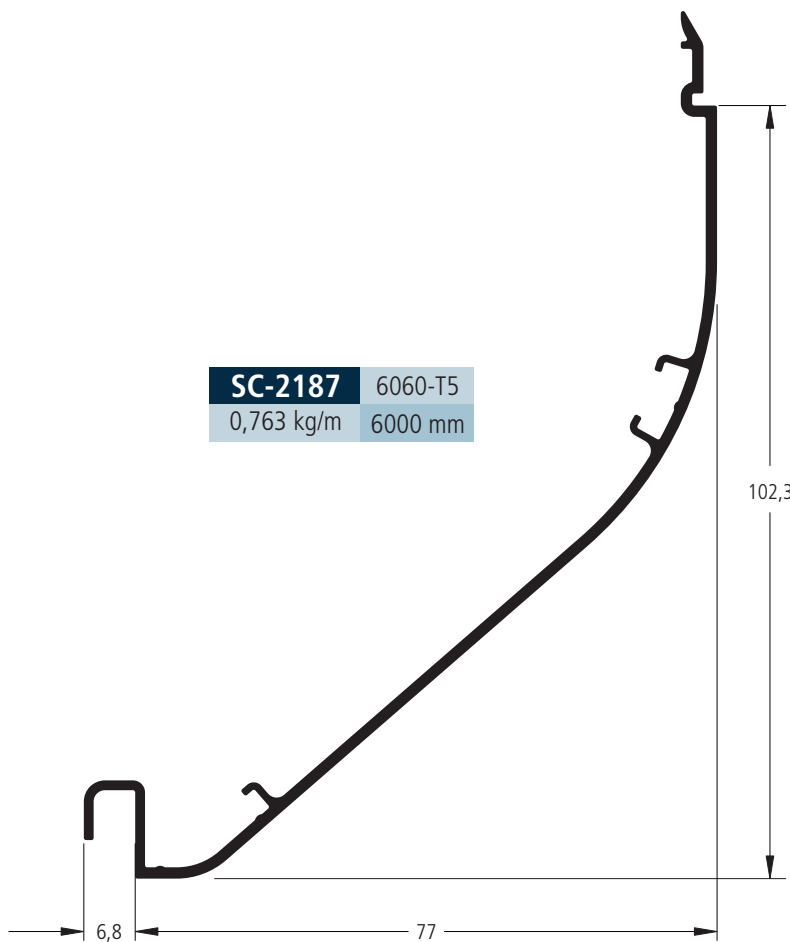

SC-2187	6060-T5
0,763 kg/m	6000 mm

As informações contidas neste catálogo são de propriedade da BELMETAL e estão sujeitas a alterações sem aviso prévio. Verifique o site www.belmetal.com.br para obter a versão mais atualizada.

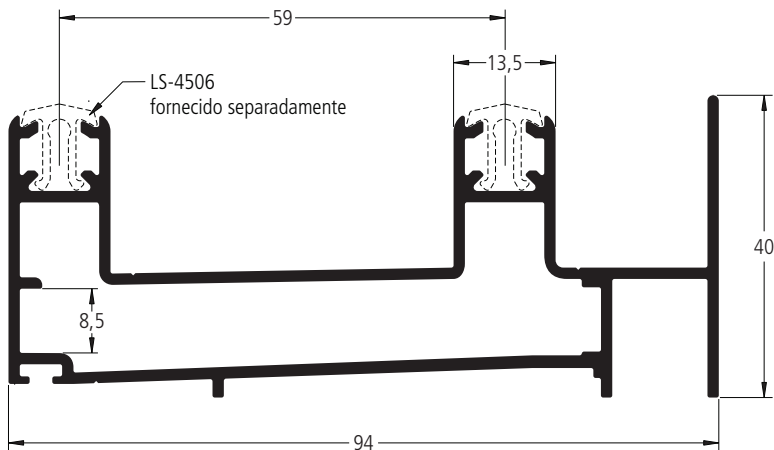

LS-4504	6060-T5
1,435 Kg/m	6000 mm

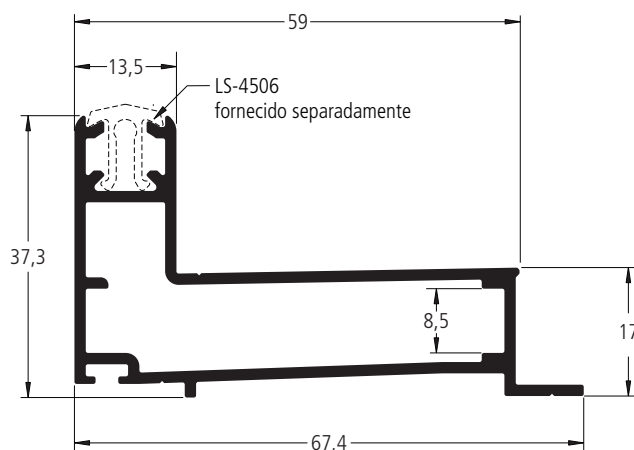

LS-4505	6060-T5
0,881 Kg/m	6000 mm

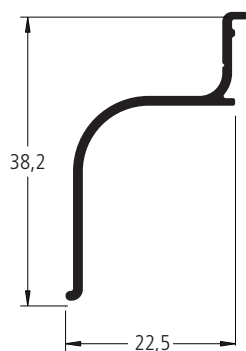

LS-4509	6060-T5
0,199 Kg/m	6000 mm

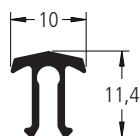

LS-4506	6060-T5
0,097 Kg/m	6000 mm

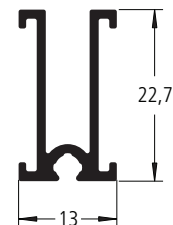

SI-3748	6060-T5
0,236 Kg/m	3000 mm

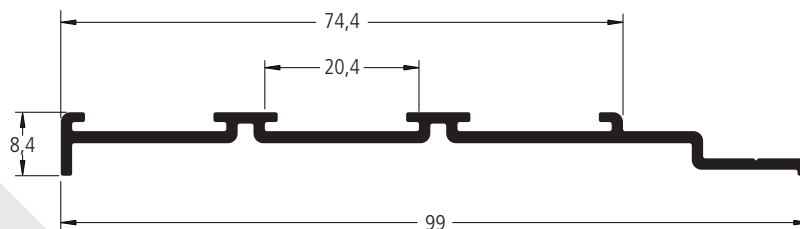

6201	6060-T5
0,547 Kg/m	6000 mm

As informações contidas neste catálogo são de propriedade da BELMETAL e estão sujeitas a alterações sem aviso prévio. Verifique o site www.belmetal.com.br para obter a versão mais atualizada.

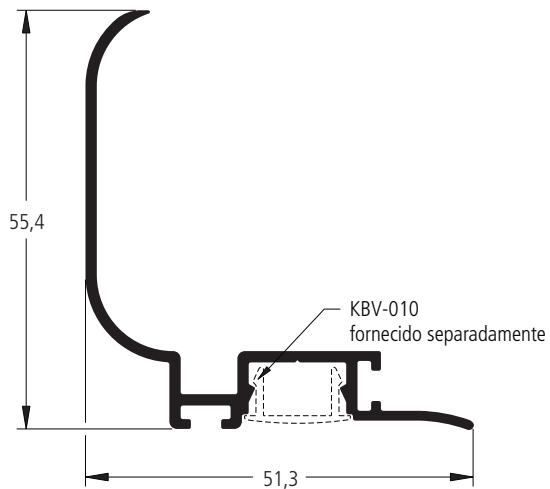

LS-4531 6060-T5
0,511 Kg/m 6000 mm

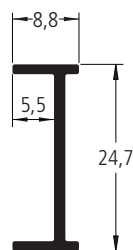

LS-4532 6060-T5
0,152 Kg/m 6000 mm

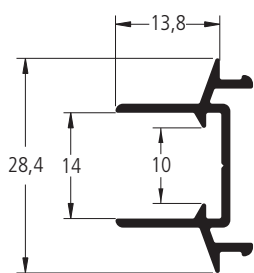

SI-3716 6060-T5
0,226 kg/m 6000 mm

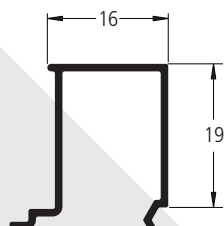

LS-4502 6060-T5
0,175 Kg/m 6000 mm

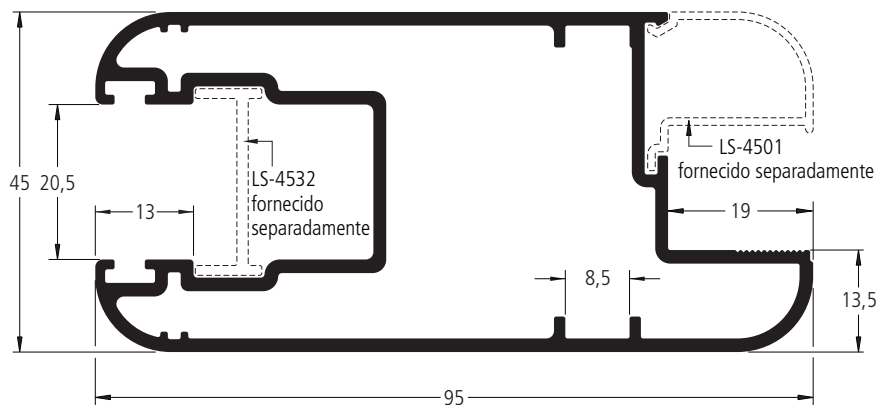

LS-4507 6060-T5
1,744 Kg/m 6000 mm

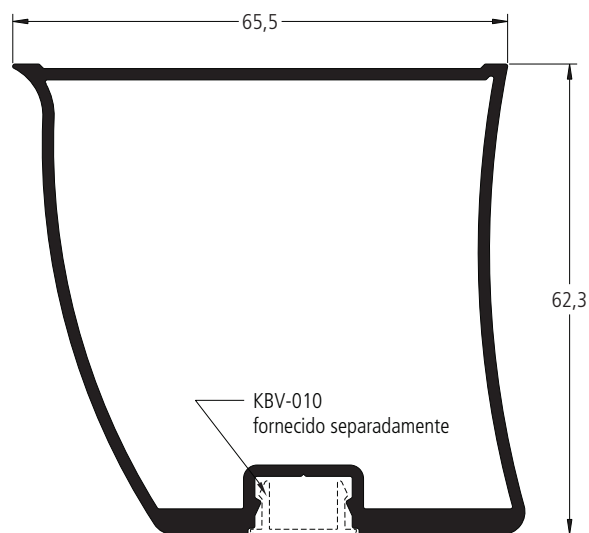

LS-4508 6060-T5
1,172 Kg/m 6000 mm

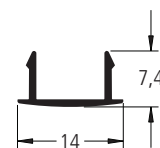

KBV-010 6060-T5
0,070 Kg/m 6000 mm

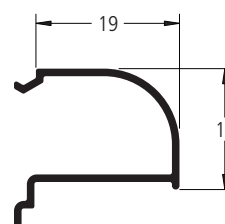

LS-4501 6060-T5
0,164 Kg/m 6000 mm

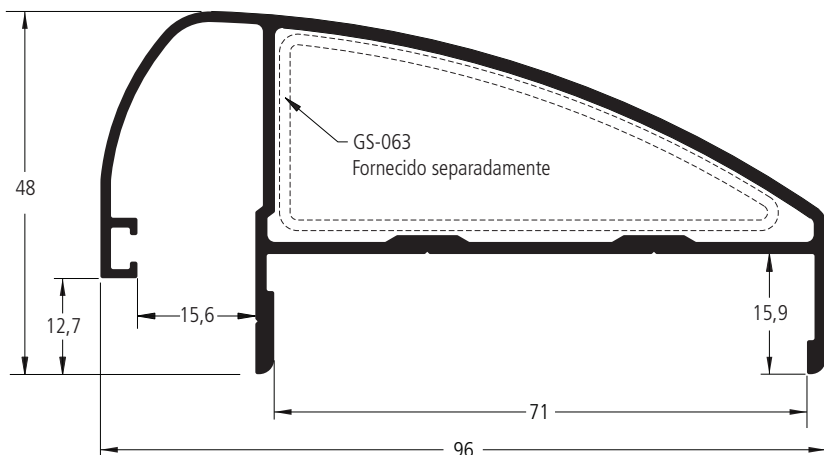

GS-066	6060-T5
1,227 kg/m	6000 mm

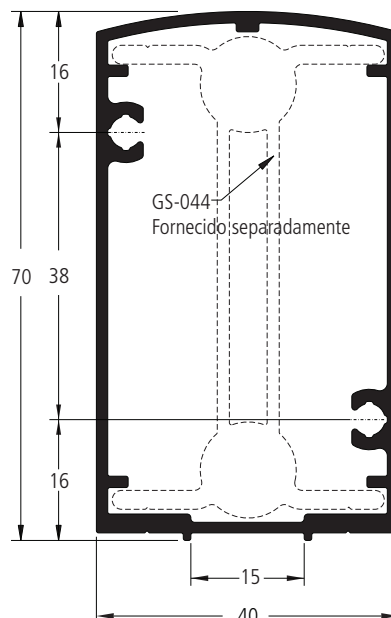

GS-043	6060-T5
1,067 kg/m	6000 mm

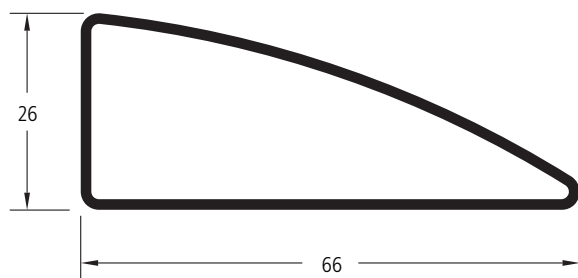

GS-063	6060-T5
0,601 kg/m	6000 mm

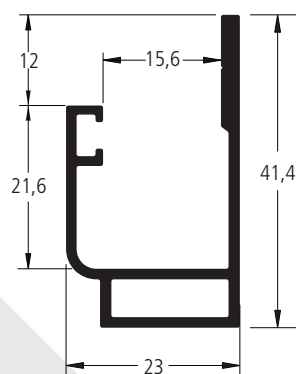

GS-055	6060-T5
0,481 kg/m	6000 mm

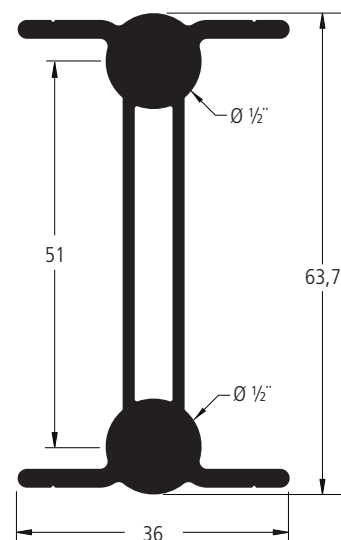

GS-044	6351-T6
1,376 kg/m	6000 mm

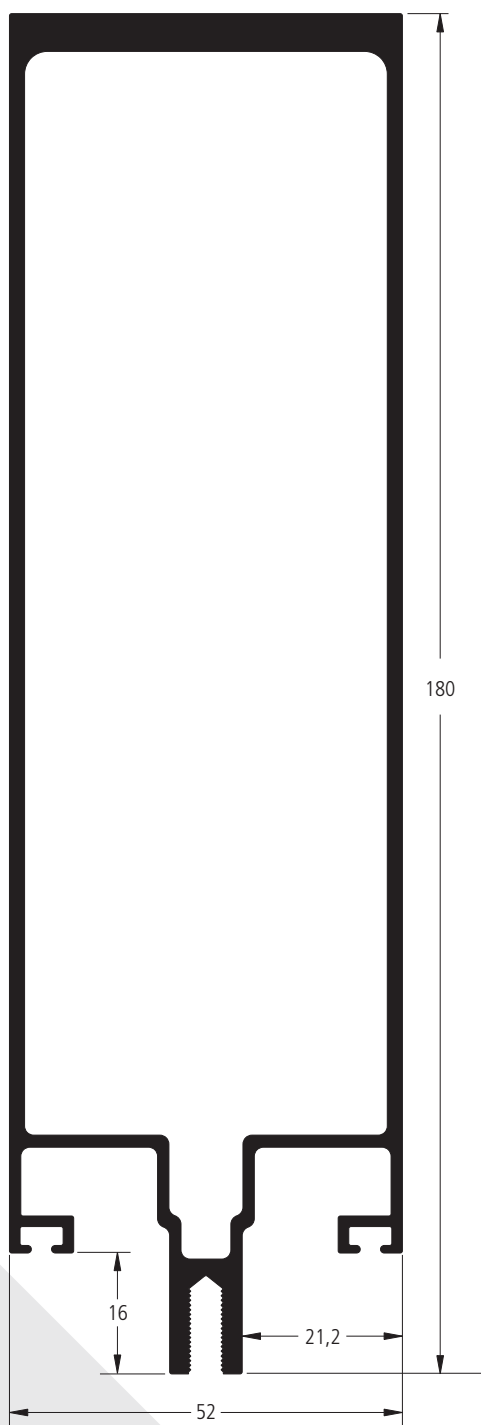

4047 6060-T5
3,137 kg/m 6000 mm

Jx 462,8591 cm⁴
Wx 47,6045 cm³

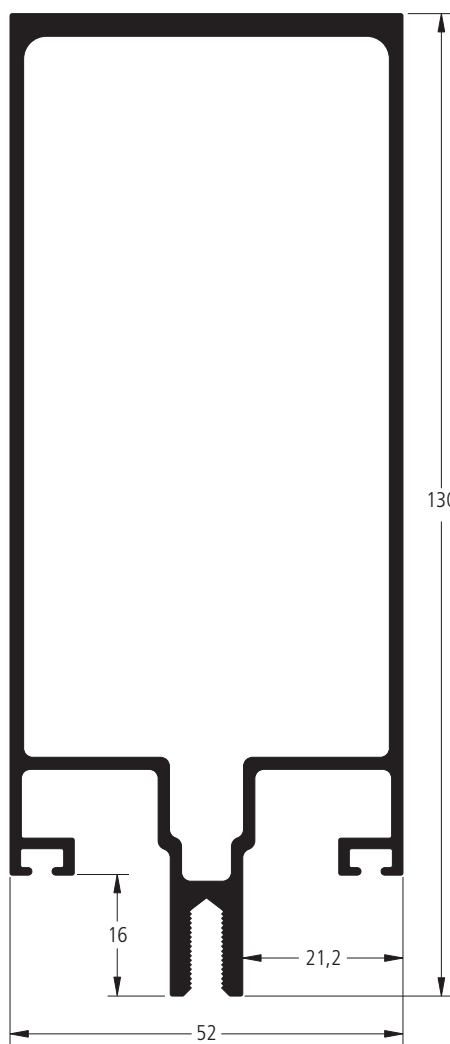

4046 6060-T5
2,145 kg/m 6000 mm

Jx 158,9491 cm⁴
Wx 23,5620 cm³

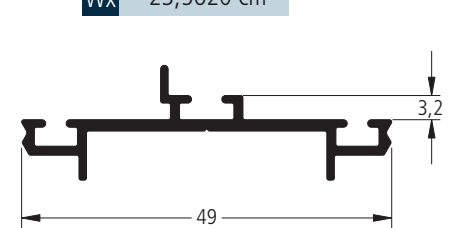

4050 6060-T5
0,306 kg/m 6000 mm

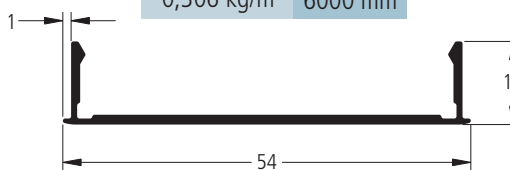

4052 6060-T5
0,246 kg/m 6000 mm

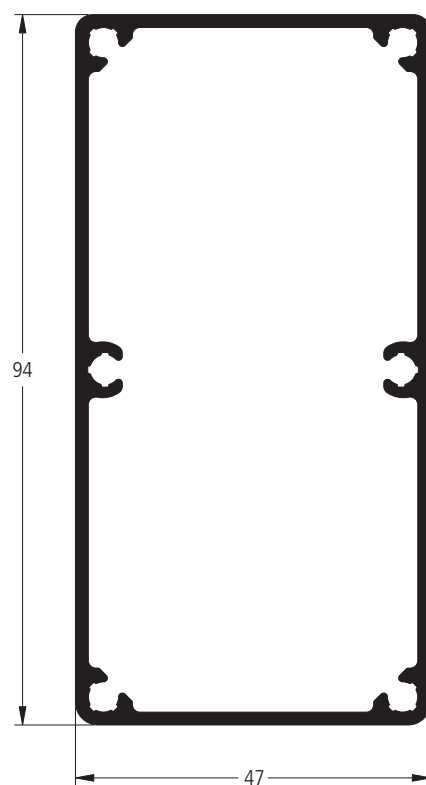

4044 6060-T5
1,451 kg/m 3000 mm

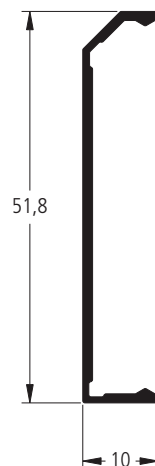

4051 6060-T5
0,225 kg/m 6000 mm

As informações contidas neste catálogo são de propriedade da BELMETAL e estão sujeitas a alterações sem aviso prévio. Verifique o site www.belmetal.com.br para obter a versão mais atualizada.

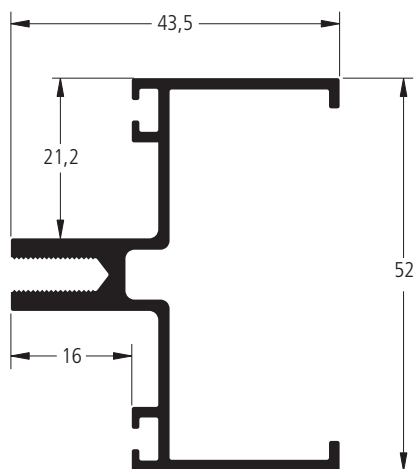

4040	6060-T5
0,743 Kg/m	6000 mm

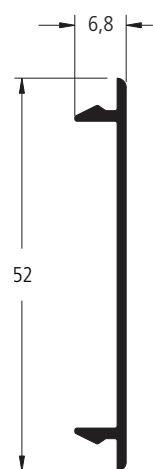

4039	6060-T5
0,212 kg/m	6000 mm

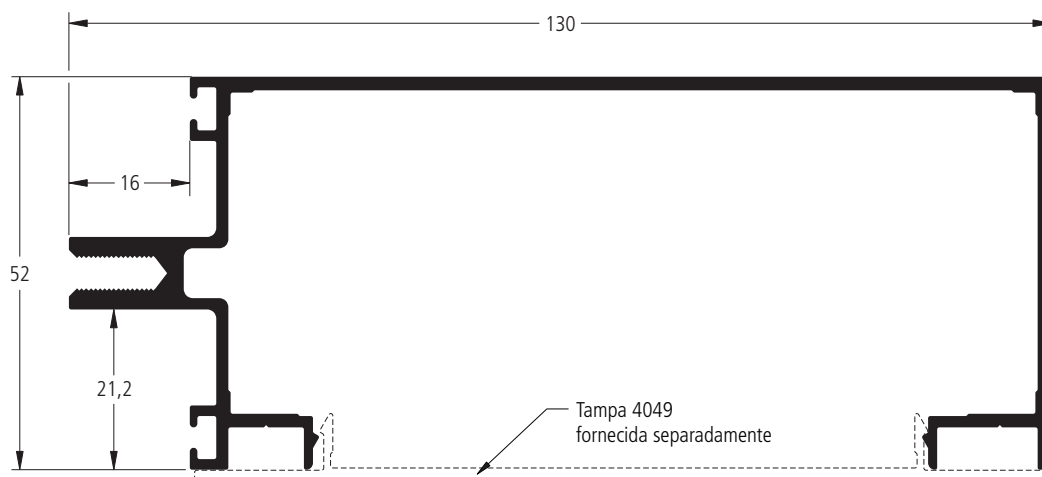

4048	6060-T5
1,505 Kg/m	6000 mm

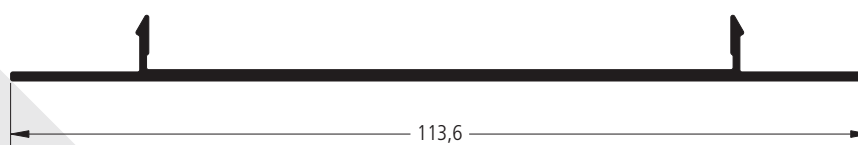

4049	6060-T5
0,477 Kg/m	6000 mm

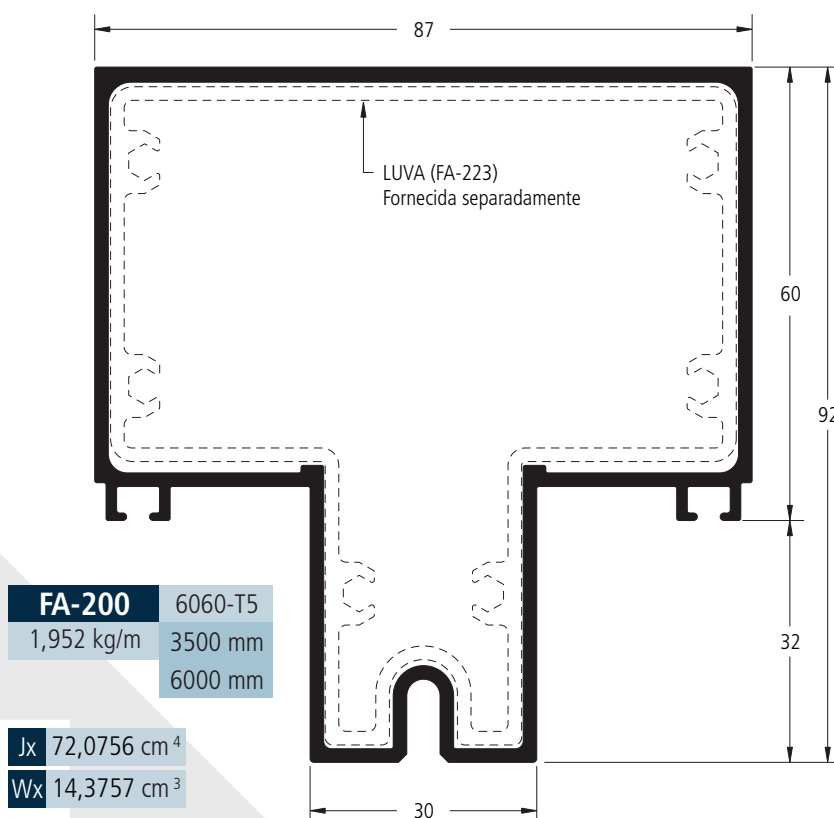
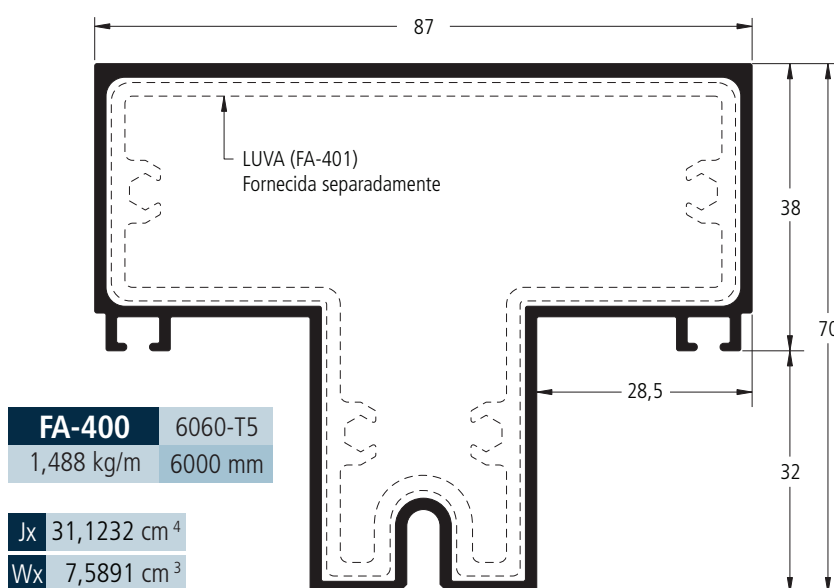
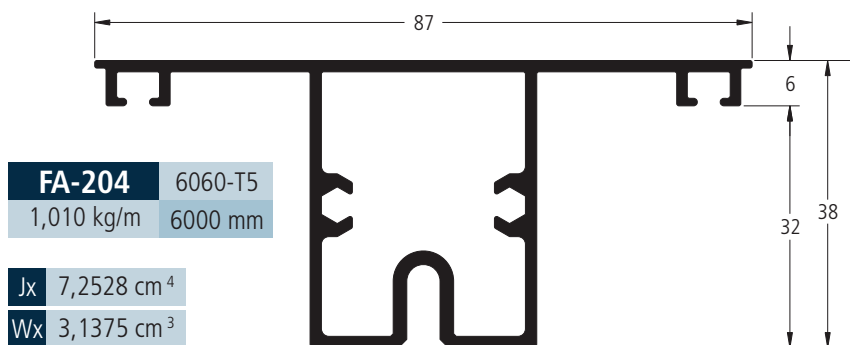

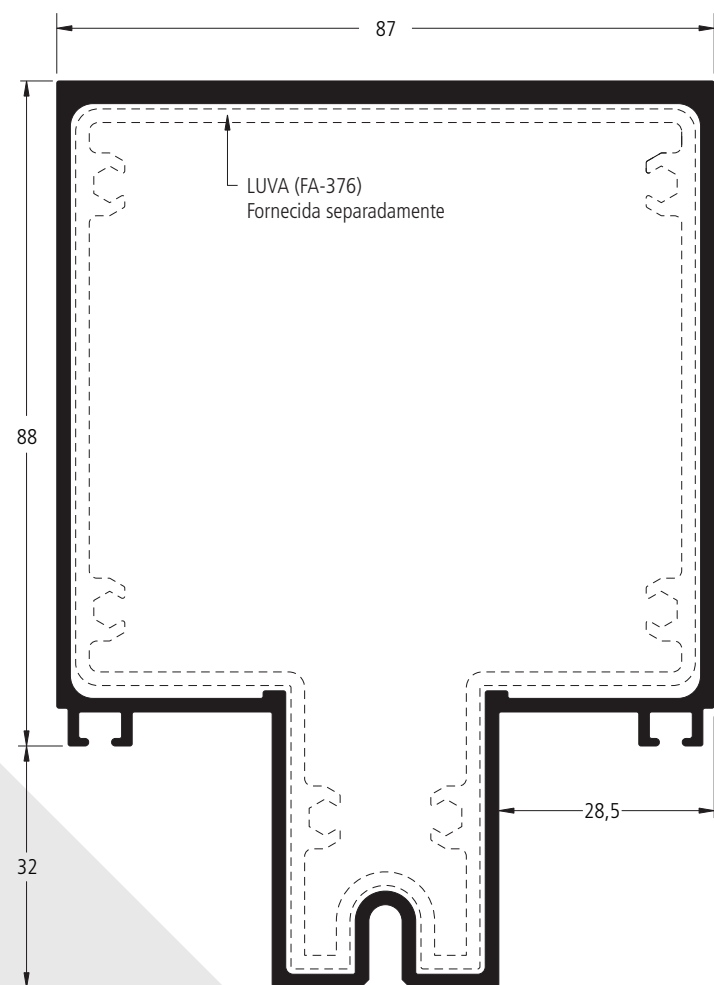

FA-375	6060-T5
2,454 kg/m	6000 mm

J_x	166,1756 cm ⁴
W_x	24,5255 cm ³

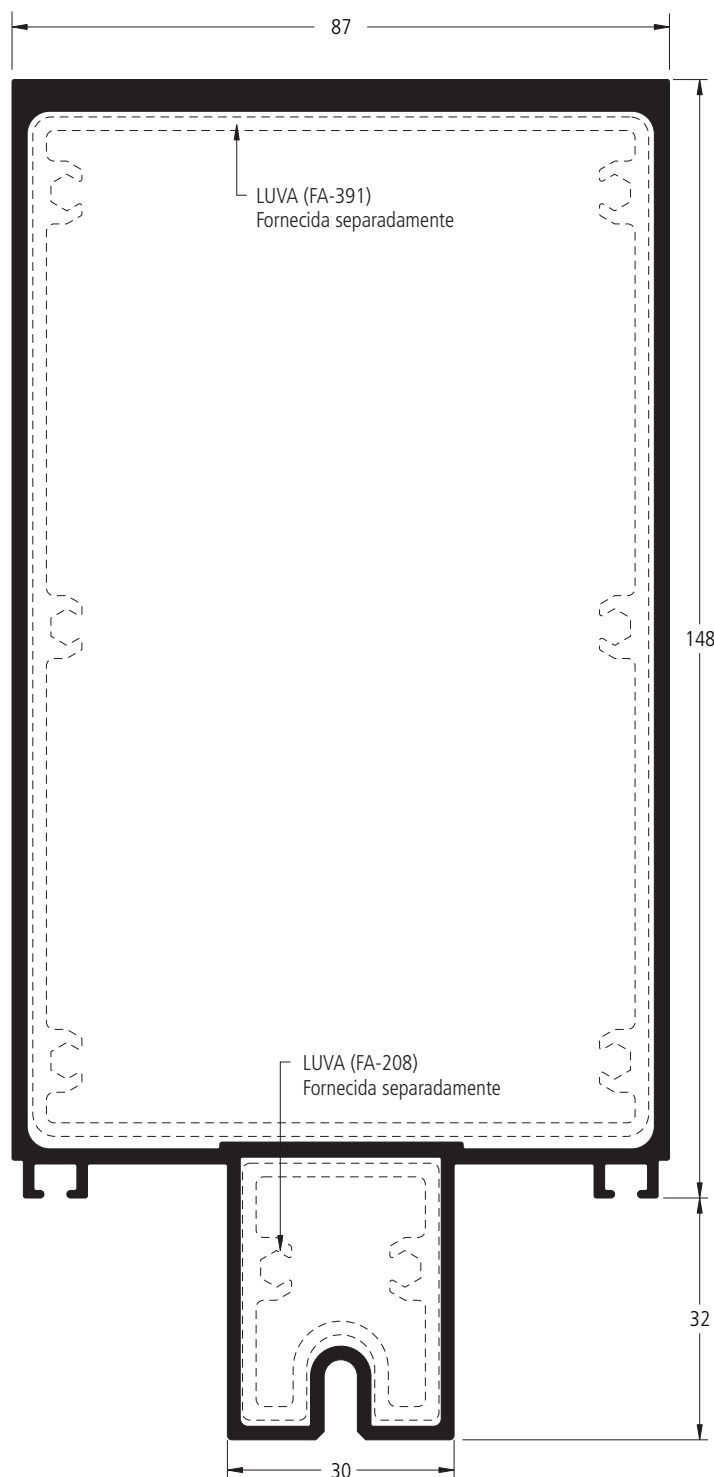

FA-390	6060-T5
3,630 kg/m	6500 mm

J_x	547,6268 cm ⁴
W_x	54,9329 cm ³

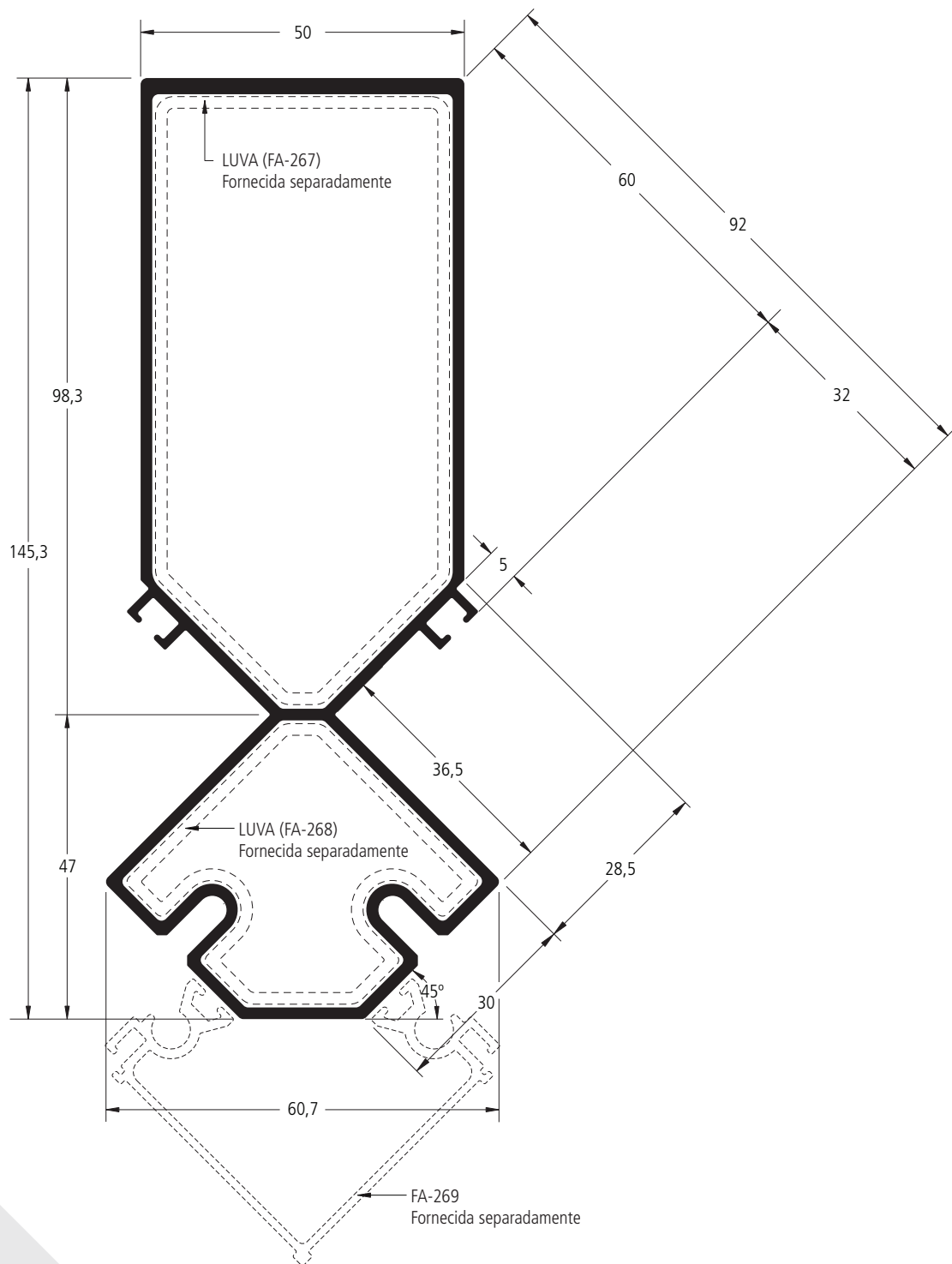

FA-236	6060-T5
2,364 kg/m	6000 mm

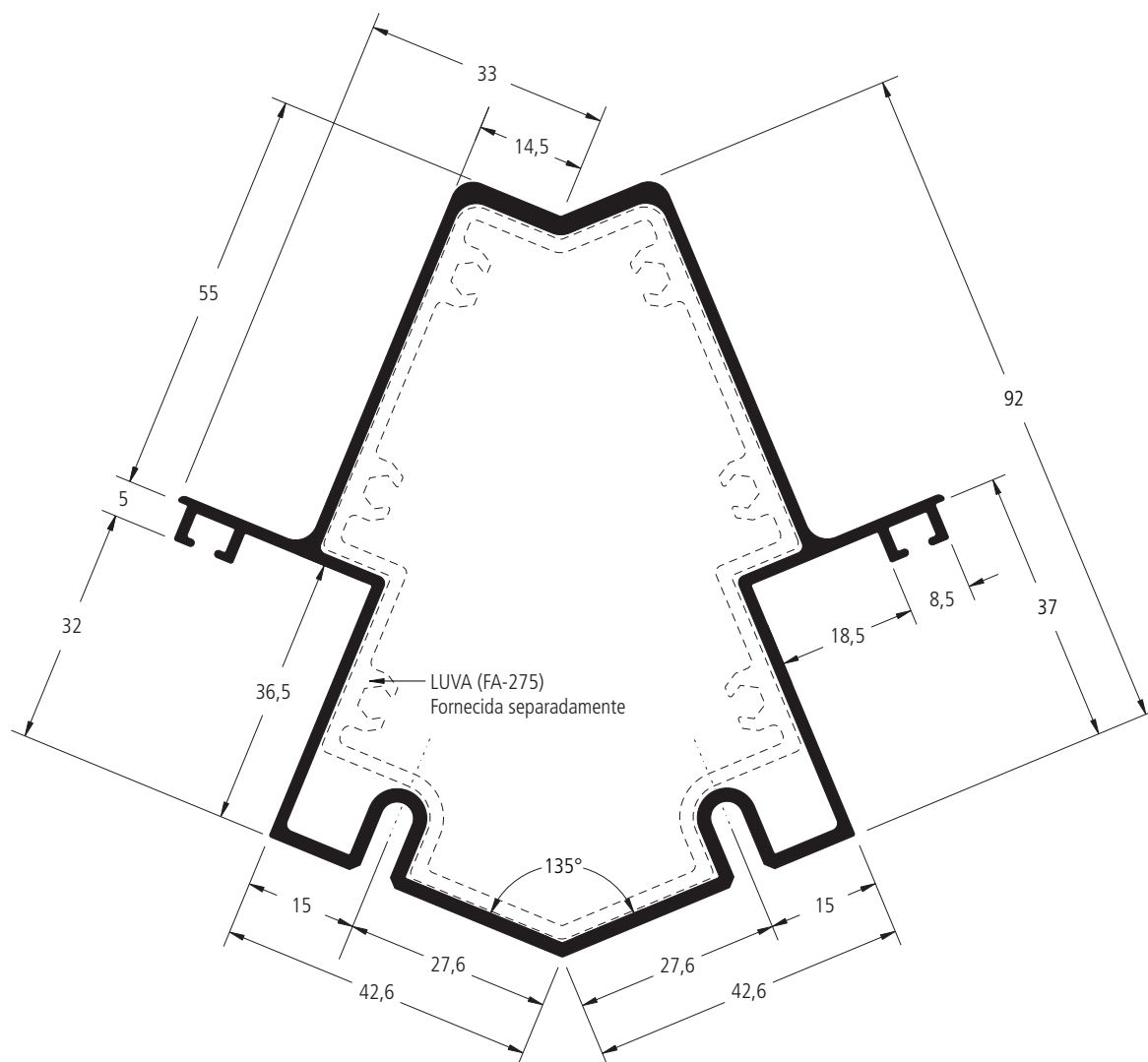

FA-244	6060-T5
1,824 kg/m	6000 mm

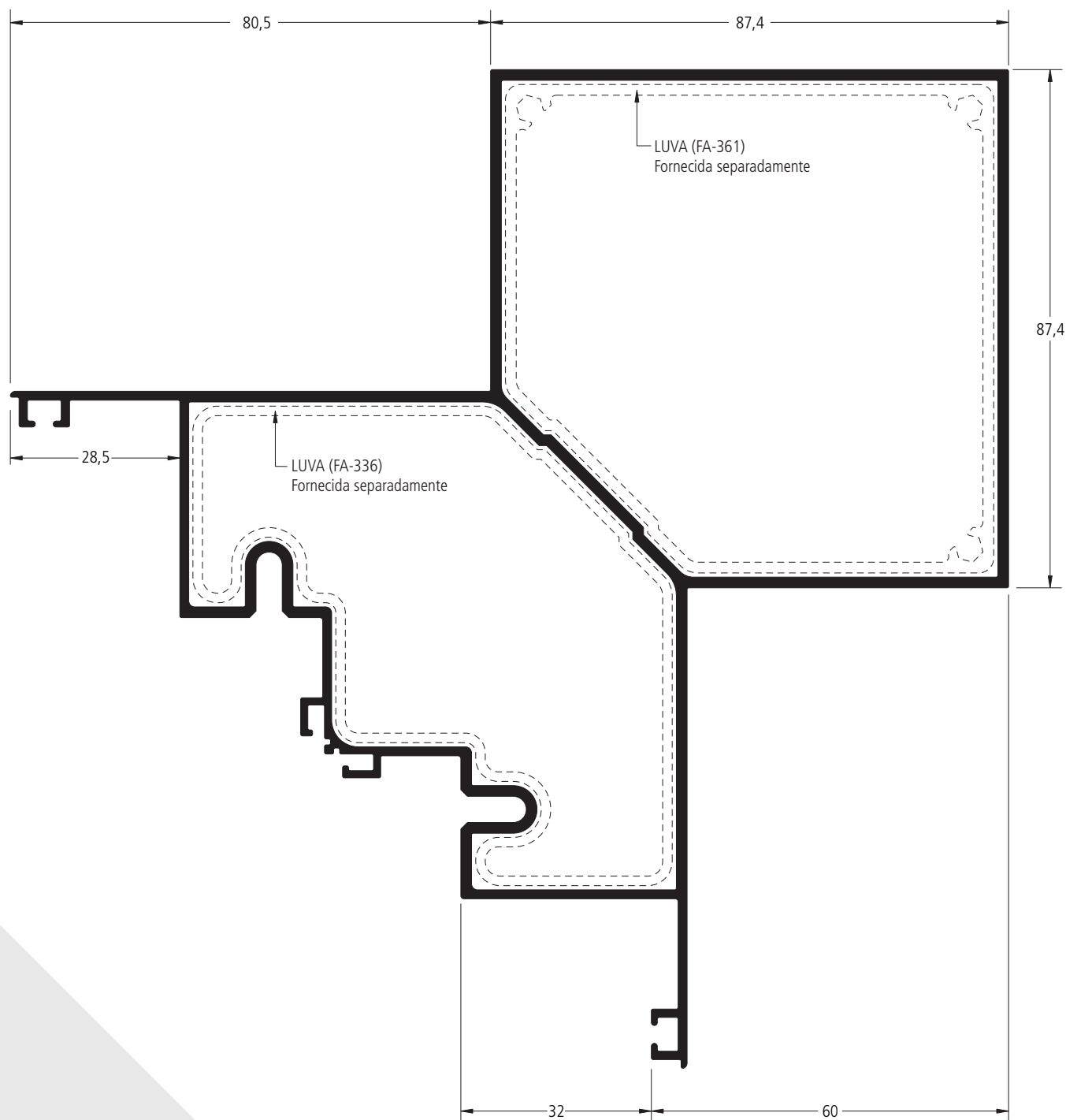

FA-360	6060-T5
3,912 kg/m	6000 mm

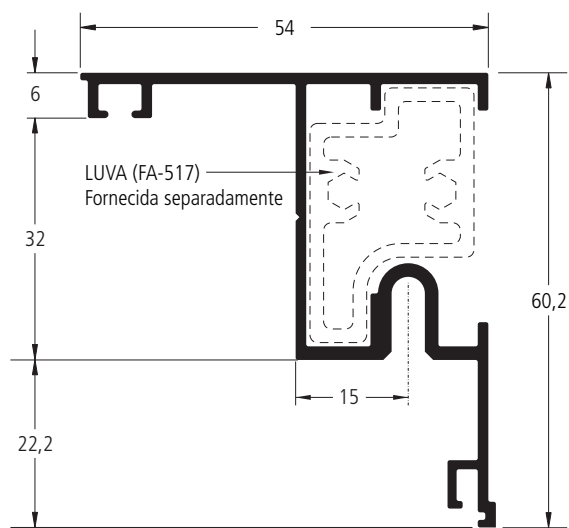

FA-294	6060-T5
0,785 kg/m	6000 mm

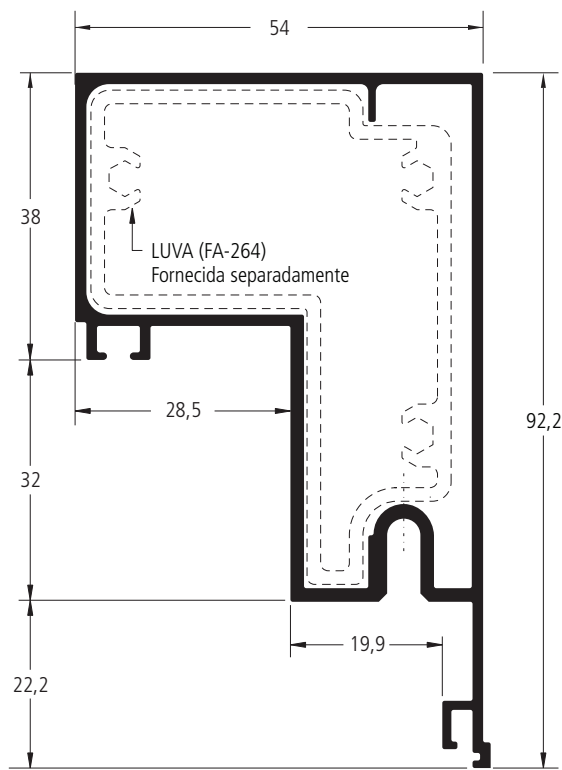

FA-347	6060-T5
1,330 kg/m	6000 mm

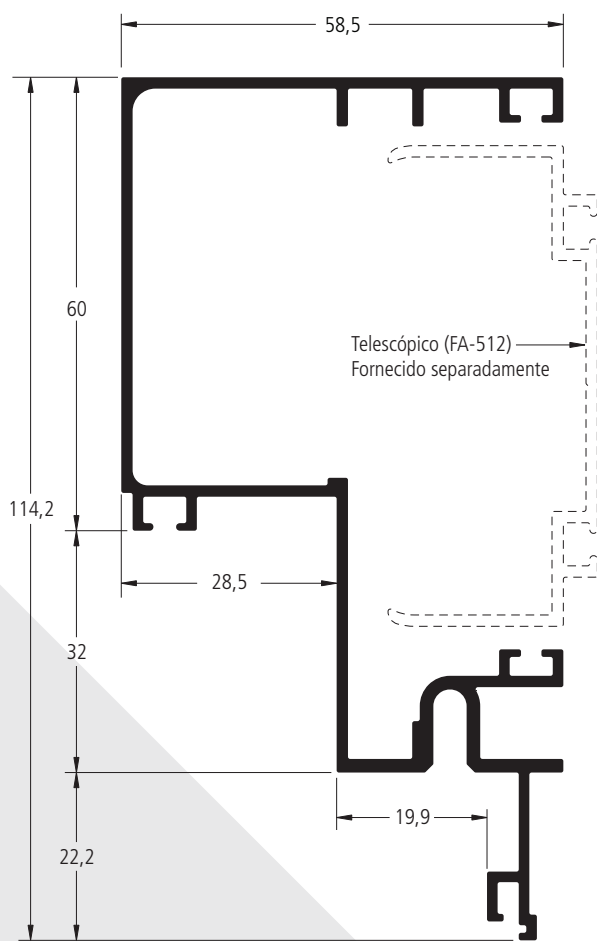

FA-511	6060-T5
1,318 kg/m	6000 mm

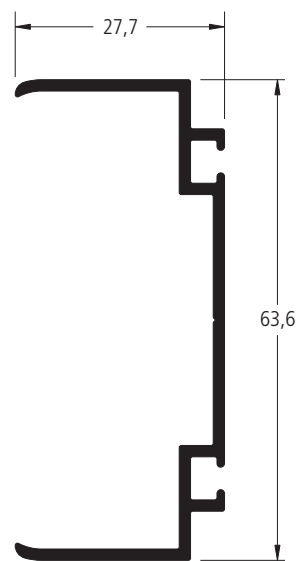

FA-512	6060-T5
0,521 kg/m	6000 mm

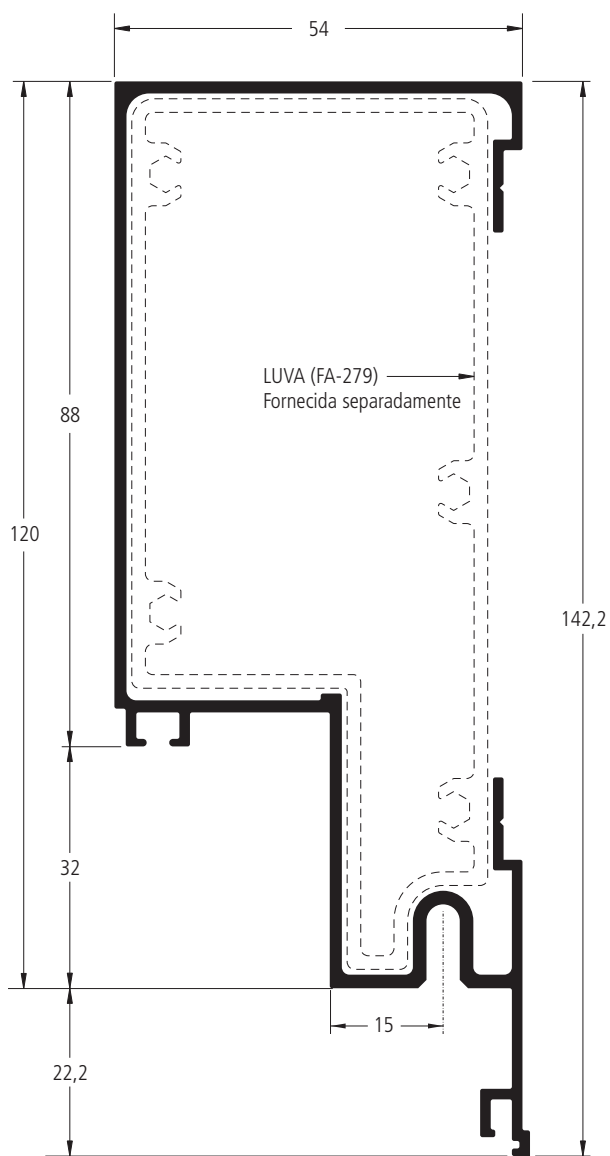

FA-278	6060-T5
1,453 kg/m	6000 mm

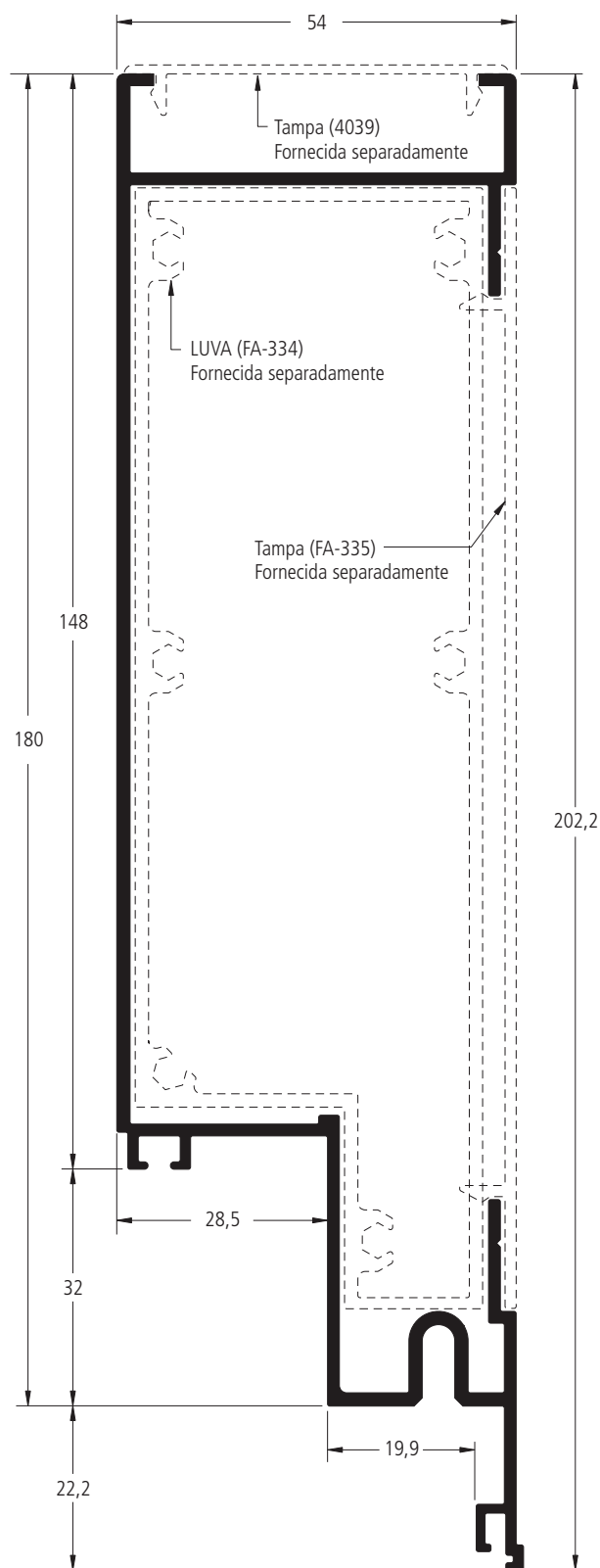

FA-333	6060-T5
2,106 kg/m	6500 mm

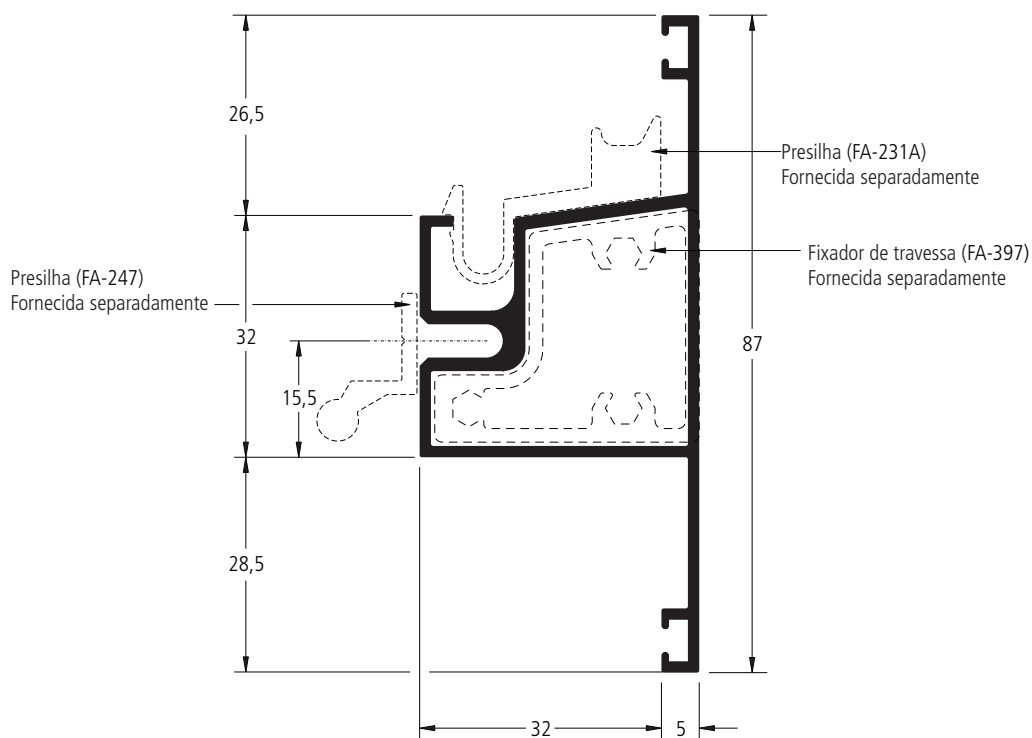

FA-211	6060-T5
0,993 kg/m	6000 mm

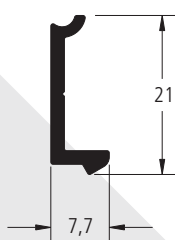

FA-240	6060-T5
0,135 kg/m	3000 mm

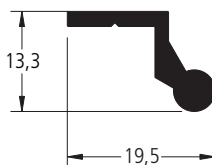

FA-247	6060-T5
0,210 kg/m	6000 mm

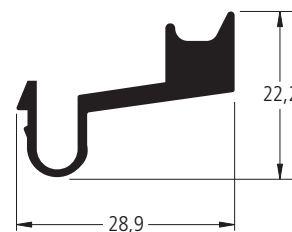

FA-231A	6060-T5
0,384 kg/m	6000 mm

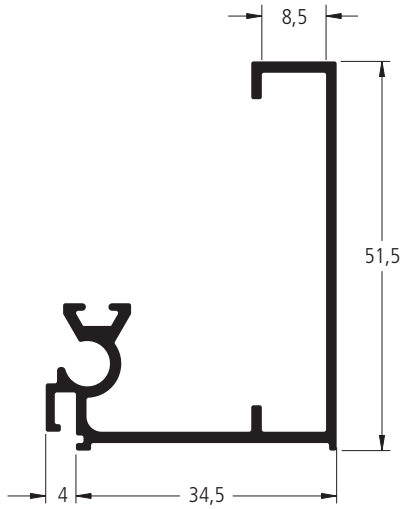

FA-228 6060-T5
0,568 kg/m 6000 mm

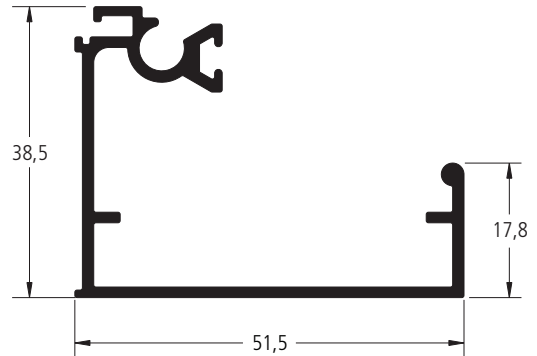

FA-232 6060-T5
0,603 kg/m 6000 mm

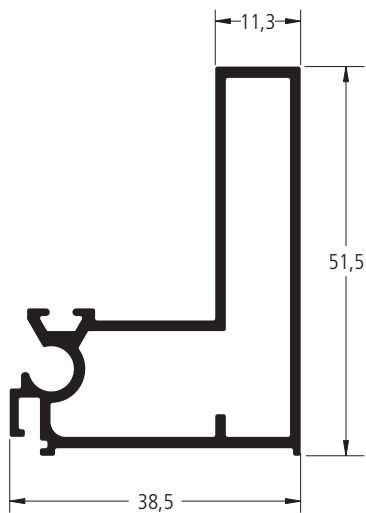

FA-245 6060-T5
0,742 kg/m 6000 mm

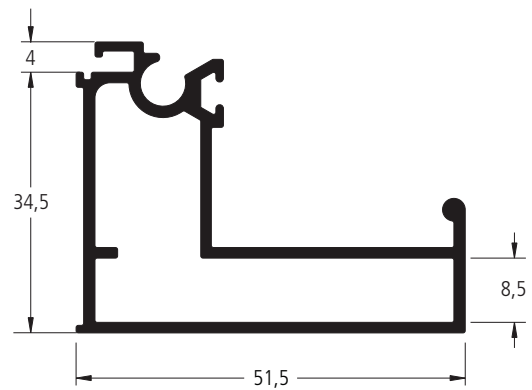

FA-230 6060-T5
0,777 kg/m 6000 mm

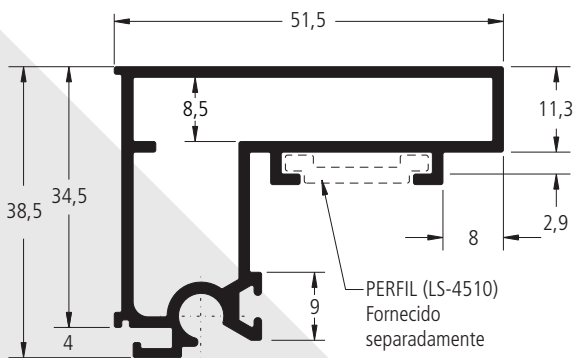

FA-276 6060-T5
0,794 kg/m 6000 mm

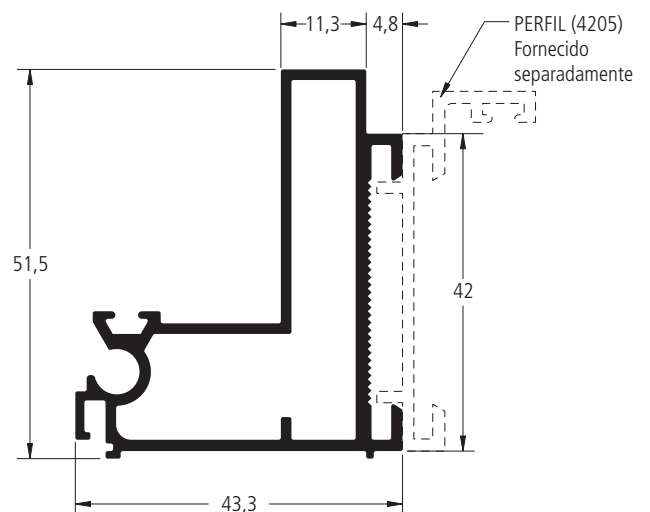

FA-291 6060-T5
0,875 kg/m 6000 mm

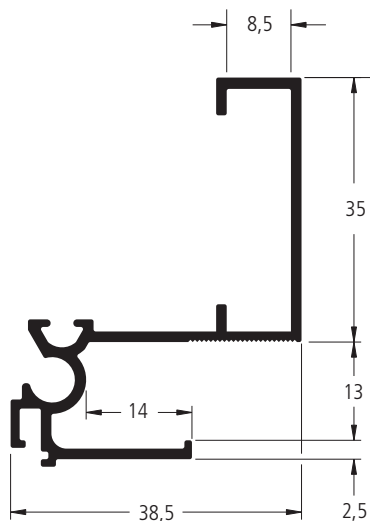

FA-404	6060-T5
0,540 kg/m	6000 mm

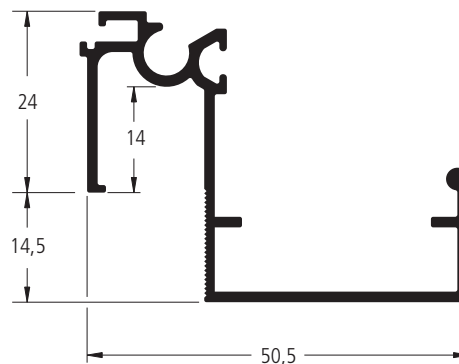

FA-406	6060-T5
0,574 kg/m	6000 mm

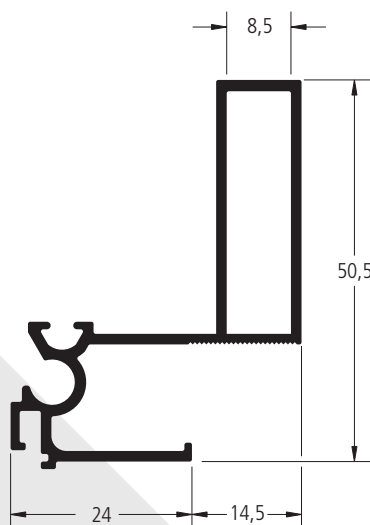

FA-403	6060-T5
0,634 kg/m	6000 mm

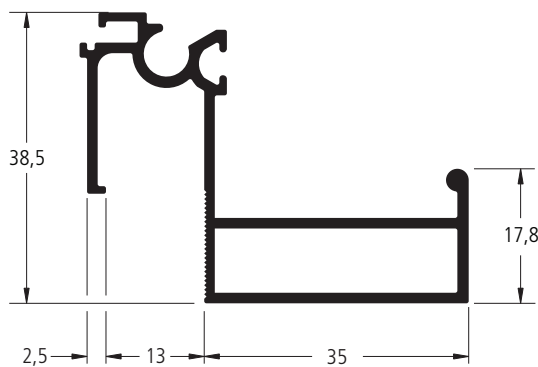

FA-405	6060-T5
0,669 kg/m	6000 mm

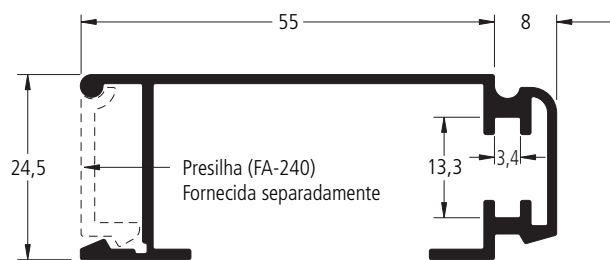

FA-239A 6060-T5
0,582 kg/m 6000 mm

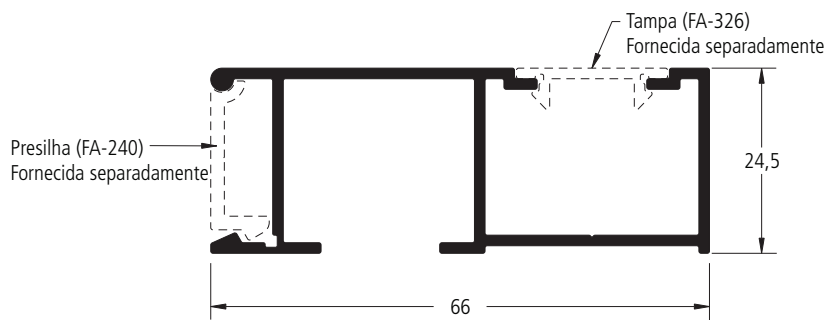

FA-325 6060-T5
0,653 kg/m 6000 mm

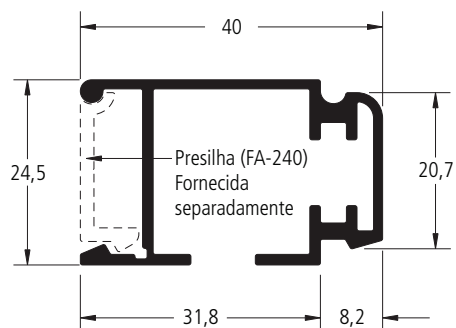

FA-293 6060-T5
0,518 kg/m 6000 mm

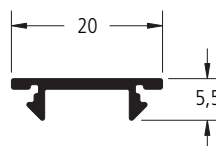

FA-326 6060-T5
0,103 kg/m 6000 mm

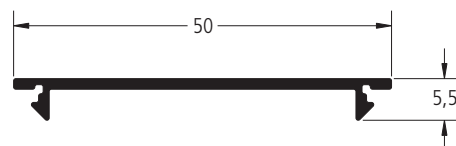

FA-299 6060-T5
0,218 kg/m 6000 mm

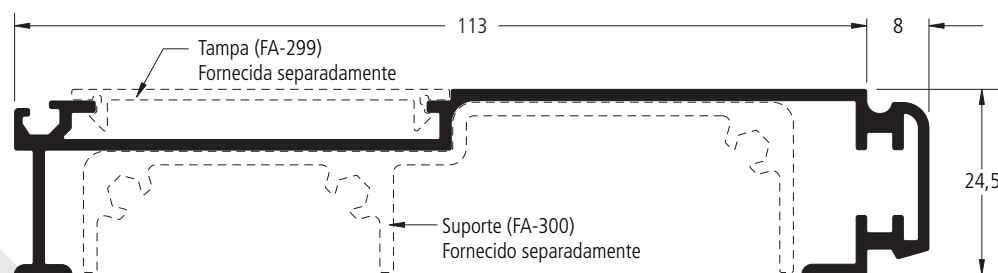

FA-265 6060-T5
0,901 kg/m 6000 mm

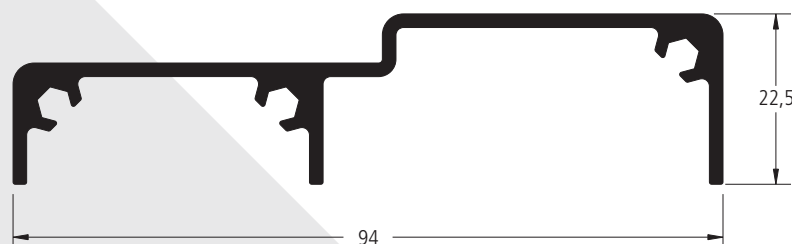

FA-300 6060-T5
0,843 kg/m 3000 mm

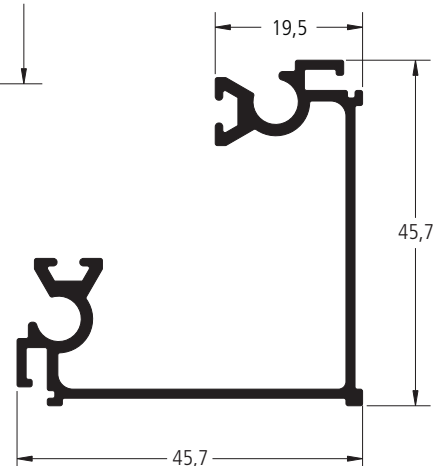

FA-269 6060-T5
0,684 kg/m 6000 mm

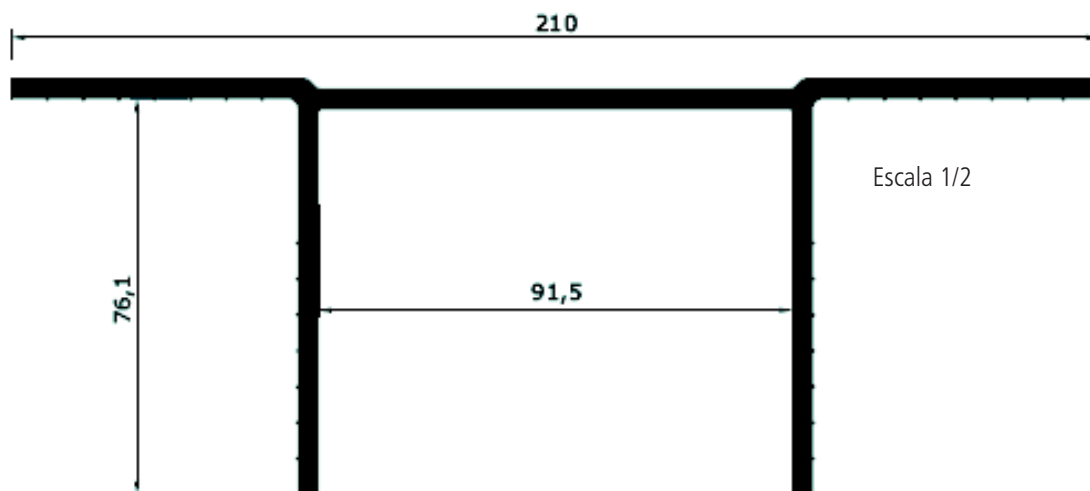

FA-226E	6351-T6
3,939 kg/m	6000 mm

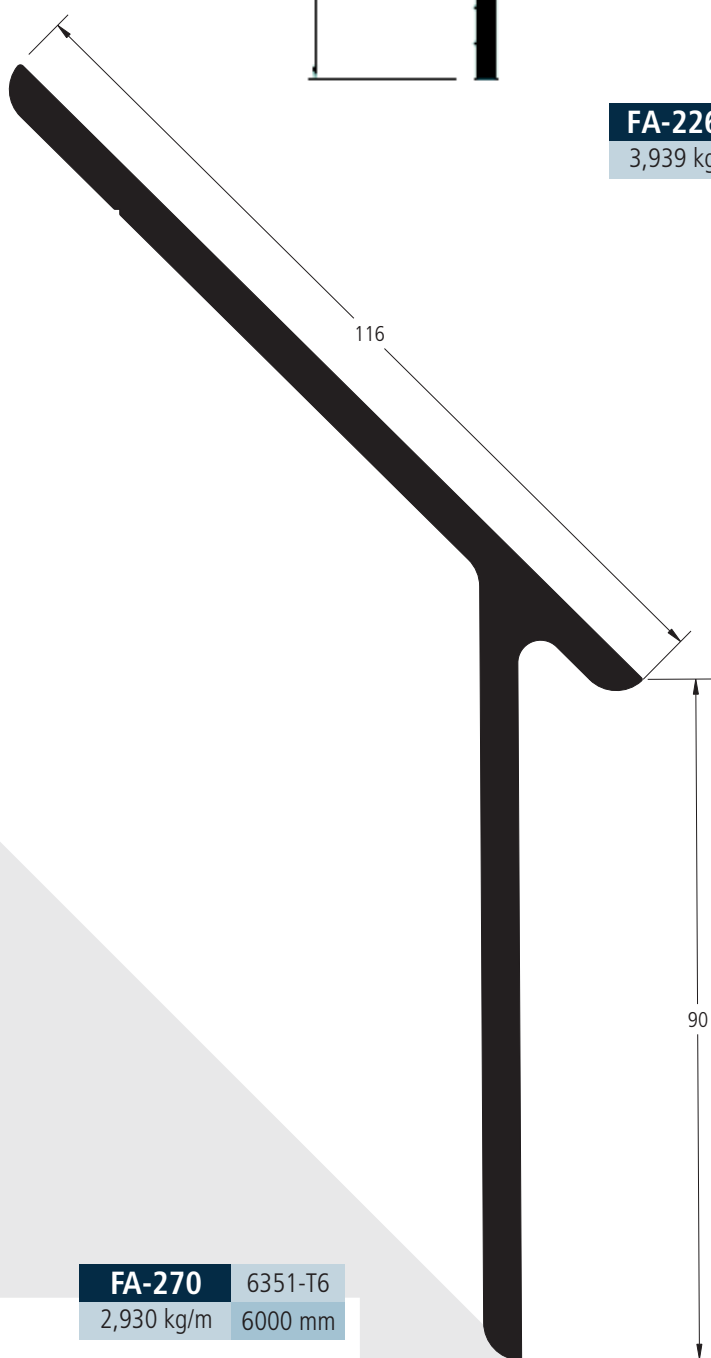

FA-270	6351-T6
2,930 kg/m	6000 mm

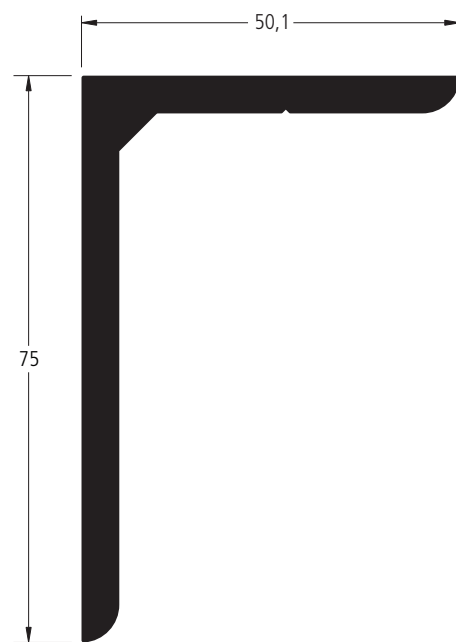

FA-271	6351-T6
1,626 kg/m	6000 mm

As informações contidas neste catálogo são de propriedade da BELMETAL e estão sujeitas a alterações sem aviso prévio. Verifique o site www.belmetal.com.br para obter a versão mais atualizada.

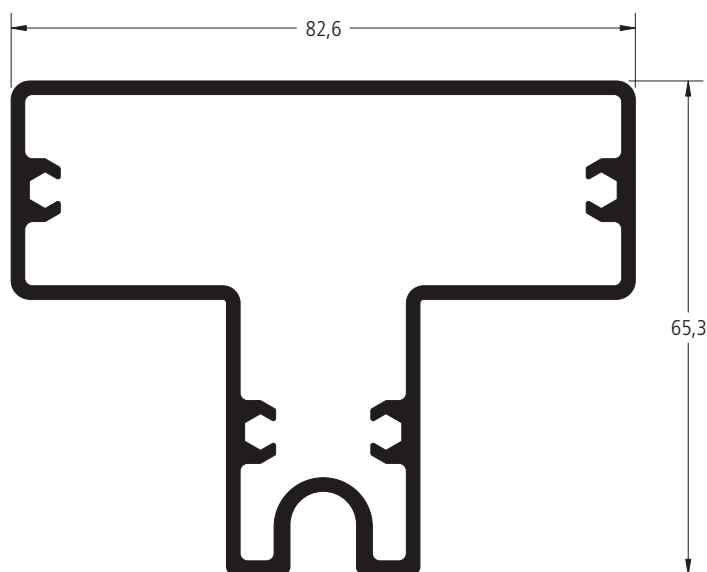

FA-401	6060-T5
1,727 kg/m	3000 mm

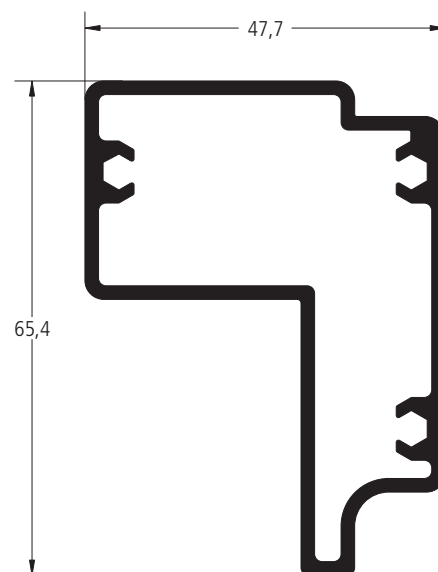

FA-264	6060-T5
1,228 kg/m	3000 mm

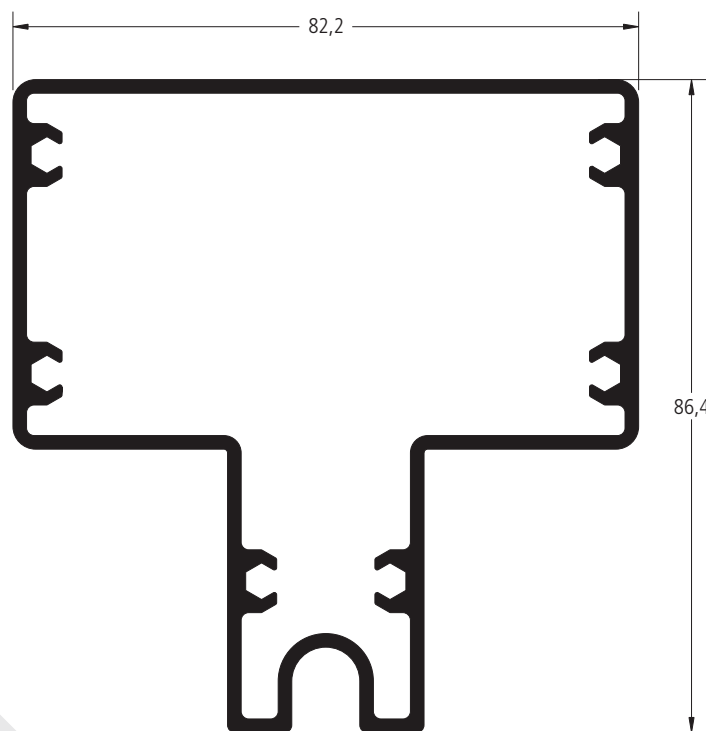

FA-223	6060-T5
1,978 kg/m	3000 mm

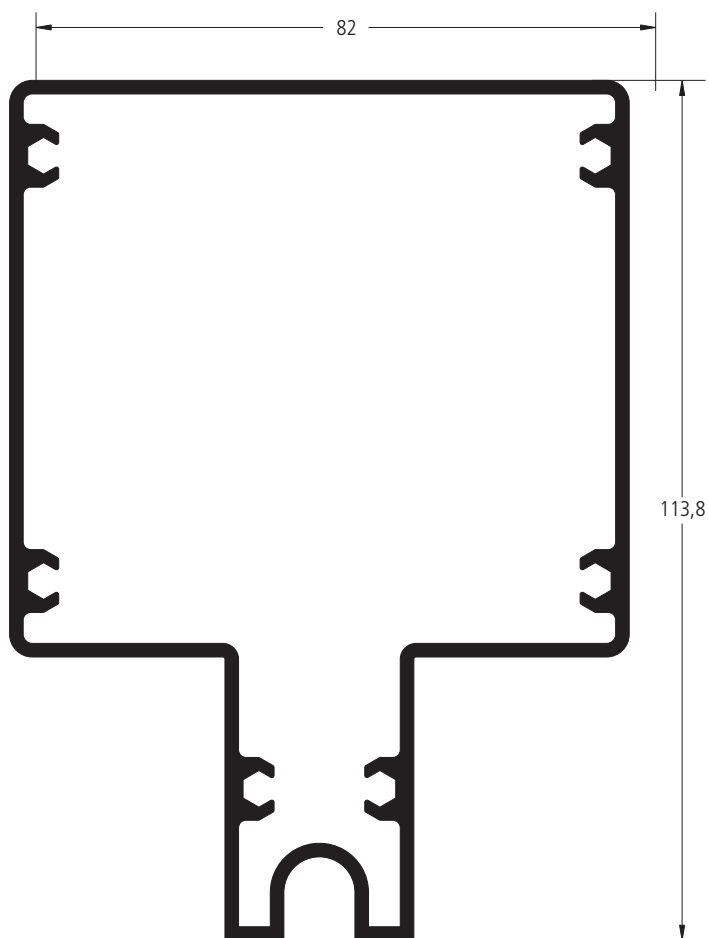

FA-376	6060-T5
2,285 kg/m	3000 mm

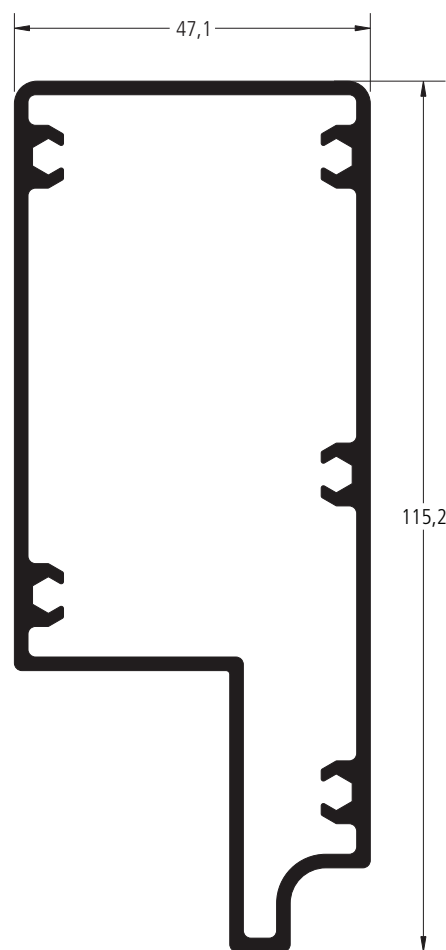

FA-279	6060-T5
1,826 kg/m	3000 mm

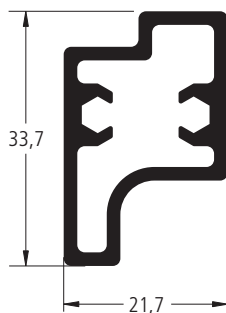

FA-517	6060-T5
0,613 kg/m	3000 mm

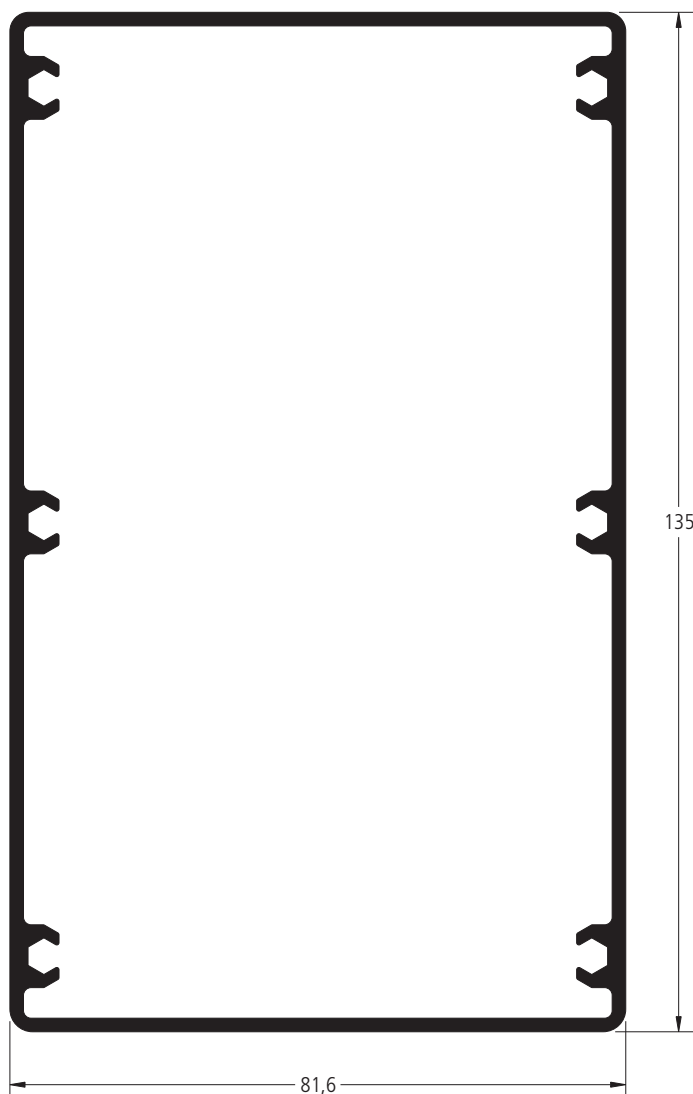

FA-391	6060-T5
2,621 kg/m	3000 mm

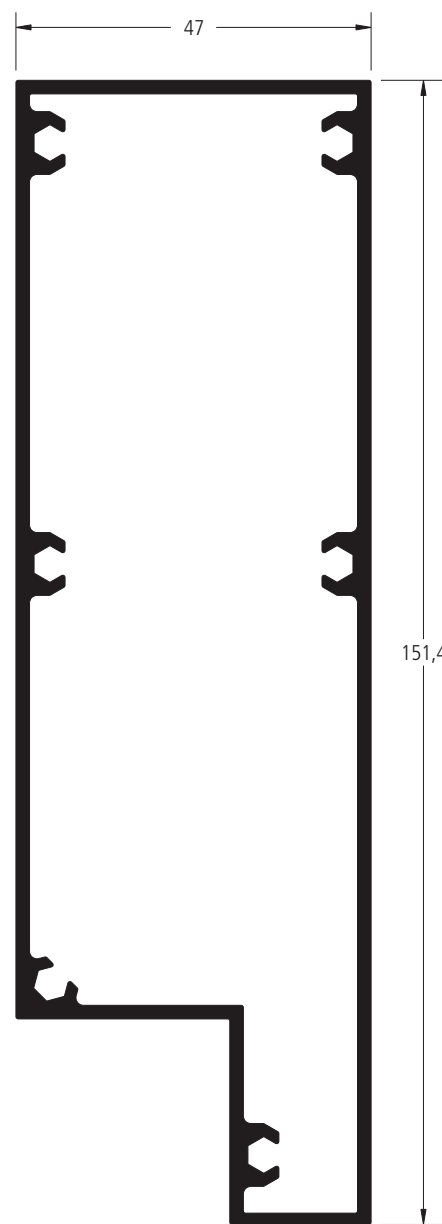

FA-334	6060-T5
2,236 kg/m	3000 mm

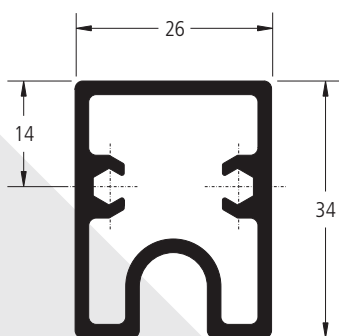

FA-208	6060-T5
0,754 kg/m	3000 mm

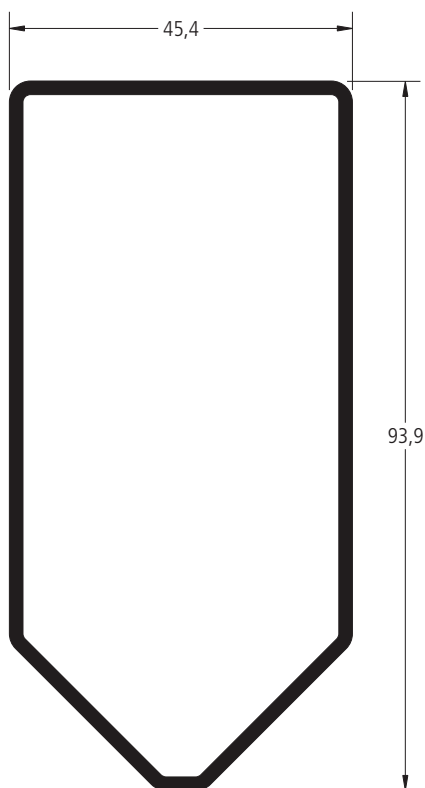

FA-267	6060-T5
1,196 kg/m	3000 mm

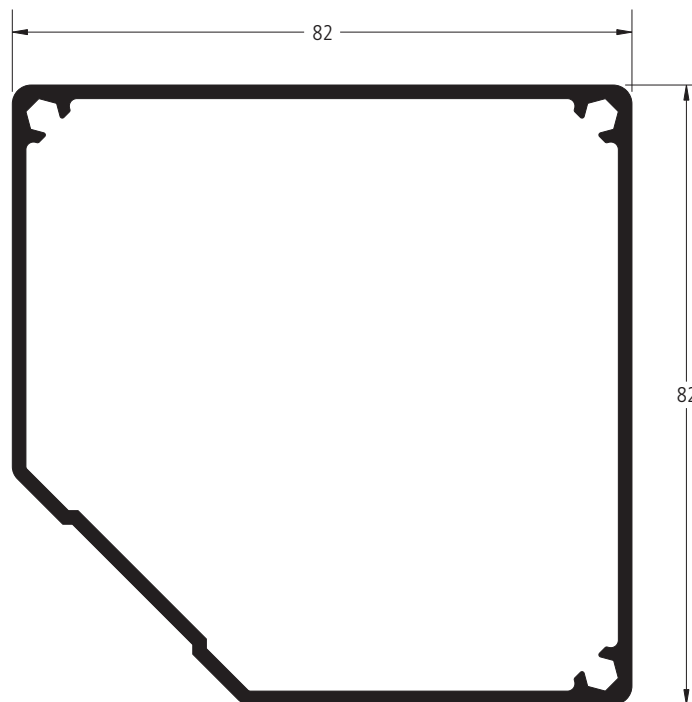

FA-361	6060-T5
1,560 kg/m	3000 mm

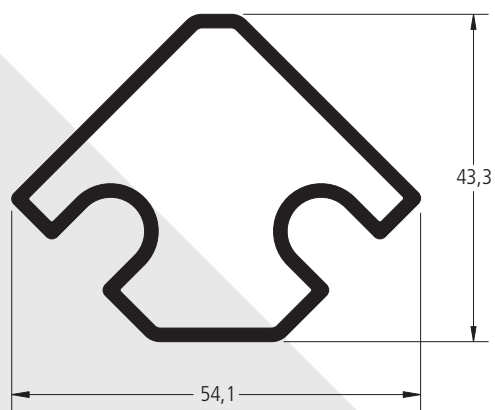

FA-268	6060-T5
0,840 kg/m	3000 mm

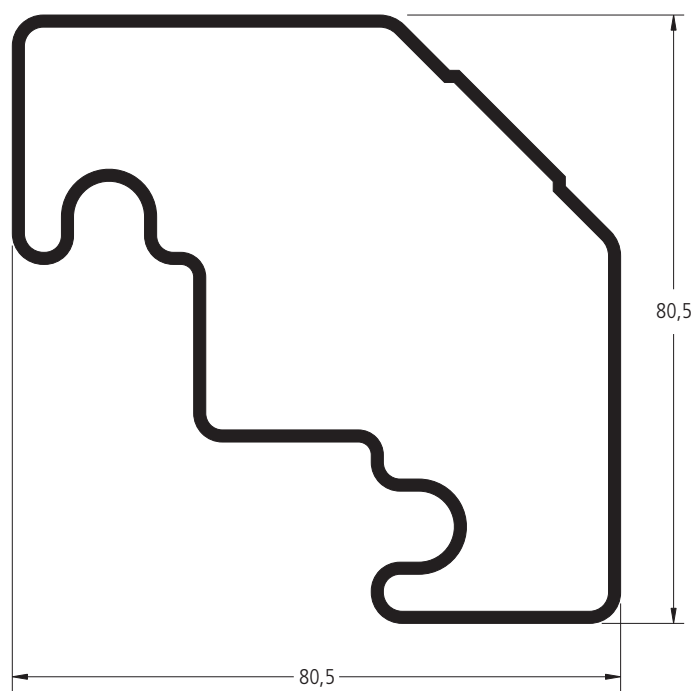

FA-336	6060-T5
1,378 kg/m	3000 mm

As informações contidas neste catálogo são de propriedade da BELMETAL e estão sujeitas a alterações sem aviso prévio. Verifique o site www.belmetal.com.br para obter a versão mais atualizada.

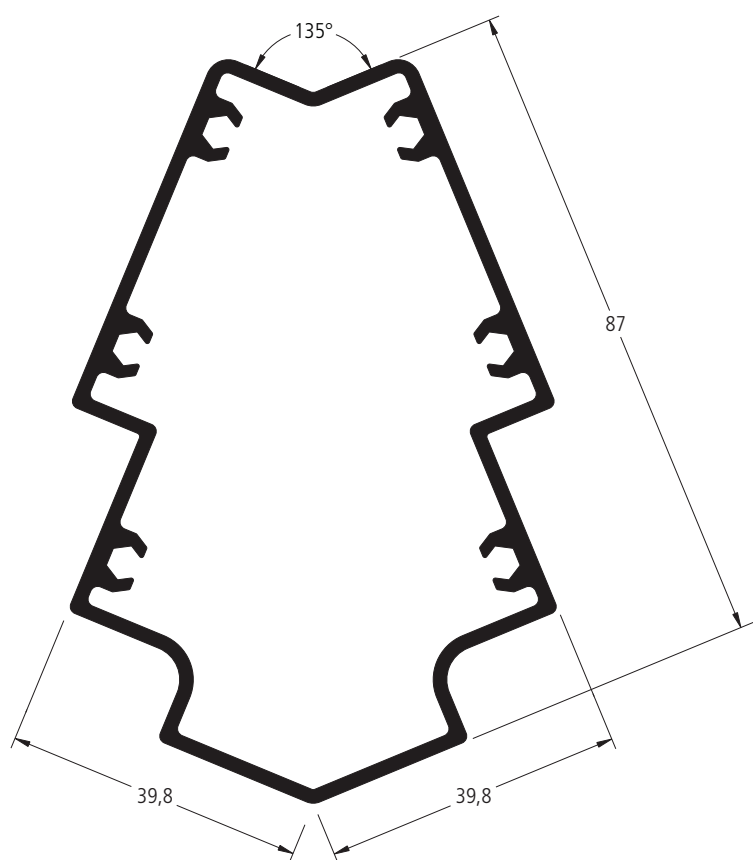

FA-275	6060-T5
1,684 kg/m	3000 mm

Sistemas de Produtos da Construção Civil:

smart 1.6

Sistema de esquadrias
para o segmento popular

smart 2.0

Sistema de esquadrias para
o segmento de médio padrão

Imperial 2.5

Sistema de esquadrias para o
segmento de médio/alto padrão

Imperial 3.5 Slim

Sistema de esquadrias para
o segmento de alto padrão

SUPERIA

Sistema diferenciado de
esquadrias para o segmento de alto padrão

Stilo Grad

Sistema de guarda-corpos

GridSky

Sistema para fachada cortina
e cobertura zenital

Atlanta

Sistema de fachadas pele de vidro e glazing

Offset

Sistema de fachada modular



belmetal

Produtos e Soluções em Alumínio

www.belmetal.com.br

perfil	descrição	peso (kg/m)	página	perfil	descrição	peso (kg/m)	página
2825	Arremate tipo "T"	0,219	PE-2.02	BLI-552E	Eixo octogonal da persiana 41mm	0,489	PE-8.04
3065E	Brise soleil	1,300	PE-5.01	BLI-555	Terminal da persiana	0,311	PE-8.04
3107	Quadro da tela mosquiteira	0,245	PE-5.01	BLI-806S	Tampa externa da caixa da persiana integrada	1,284	PE-8.06
3147E	Trilho	0,249	PE-5.01	BLI-807S	Marco superior da persiana integrada p/ janela	0,996	PE-8.02
3189E	Montante / travessa	0,945	PE-5.02	BLI-808S	Tampa da caixa da persiana integrada	0,872	PE-8.05
3190E	Montante / travessa	0,563	PE-5.02	BLI-816E	Eixo octogonal da persiana 60mm	0,792	PE-8.04
3213	Perfil U de abas desiguais longas 29 x 35	0,389	PE-1.01	BP-013E	Arremate soleira	0,268	PE-2.02
3517E	Veneziana	0,252	PE-3.01	BP-055E	Contramarco soleira	0,333	PE-2.01
4039	Tampa do marco lateral 4040/ FA-333	0,212	PE-11.02	BP-060E	Contramarco periférico	0,223	PE-2.01
4040	Travessa intermediária	0,743	PE-11.02	BP-098E	Contramarco soleira	0,377	PE-2.01
4044	Luva para coluna 4046	1,451	PE-11.01	BP-347E	Arremate face interna	0,197	PE-2.02
4046	Coluna com 130 mm	2,145	PE-11.01	BP-384E	Contramarco periférico	0,175	PE-2.01
4047	Coluna com 180 mm	3,137	PE-11.01	BR-403	Barra retangular 12,7 x 3,17	0,109	PE-1.01
4048	Travessa Intermediária aberta com 130mm	1,505	PE-11.02	BR-408	Barra retangular 15,87 x 4,76	0,204	PE-1.01
4049	Tampa da travessa intermediária aberta 4048	0,477	PE-11.02	BR-412	Barra retangular 19,05 x 4,76	0,245	PE-1.01
4050	Presilha do vidro com encaixe para tampa	0,306	PE-11.01	BR-419	Barra retangular 25,4 x 3,17	0,217	PE-1.01
4051	Tampa horizontal	0,225	PE-11.01	BR-420	Barra retangular 25,4 x 4,76	0,326	PE-1.01
4052	Tampa vertical	0,246	PE-11.01	BR-421	Barra retangular 25,4 x 6,35	0,435	PE-1.01
4205E	Mata junta para porta de giro L-42	0,369	PE-4.01	BR-422	Barra retangular 25,4 x 9,52	0,653	PE-1.01
4239E	Marco porta de giro	0,855	PE-4.01	BR-429	Barra retangular 31,75 x 9,52	0,816	PE-1.01
4251E	Montante / travessa da folha	1,373	PE-4.01	BR-454E	Barra retangular 100,00 x 3,00	0,810	PE-1.01
4294	Baguete L-42	0,209	PE-4.01	BS-501E	Marco superior - 2 planos	0,773	PE-6.01
6052E	Veneziana	0,302	PE-3.01	BS-503E	Marco lateral c/ mata junta incorp.-2 planos	0,537	PE-6.03
6201	Dreno e vedande superior	0,547	PE-9.01	BS-507E	Marco superior 3 planos	1,028	PE-6.04
7274E	Lambri duplo	0,805	PE-5.02	BS-509E	Marco lateral c/ mata junta duplo - 3 planos	0,767	PE-6.05
B-405E	Coluna / gradil	0,580	PE-5.02	BS-510E	Marco lateral c/ mata junta central - 3 planos	0,671	PE-6.05
B-413E	Barrote	0,349	PE-5.02	BS-529E	Travessa inferior / superior	0,542	PE-6.11
B-466	Marco lateral - veneziana E-565	0,280	PE-3.01	BS-533E	Marco lateral liso - 3 planos	0,559	PE-6.05
B-467	Travessa superior / inferior da veneziana	0,358	PE-3.01	BS-581E	Travessa inferior / superior	0,496	PE-6.11
B-468	Travessa inferior da veneziana	0,280	PE-3.01	BS-593	Baguete vertical com 11 mm	0,107	PE-6.12
BL-006E	Macho de conexão	1,006	PE-2.02	BS-608E	Travessa intermediária	0,574	PE-6.11
BL-011E	Cunha de conexão	0,315	PE-2.02	BS-609E	Travessa inferior da porta	0,926	PE-6.11
BLI-548S	Marco complementar para receber recolhedor	1,159	PE-8.04	BS-616	Complemento coluna	0,458	PE-6.03
BLI-549S	Marco lateral janela	0,823	PE-8.04	BS-617	Travessa intermediária p/ bandeira - 3 planos	2,140	PE-6.04

perfil	descrição	peso (kg/m)	página	perfil	descrição	peso (kg/m)	página
BS-629E	Perfil de reversão	0,214	PE-6.13	FA-264	Luva do marco lateral FA-260	1,228	PE-12.13
BS-631E	Travessa intermediária	0,586	PE-6.11	FA-265	Arremate interm. 121 mm p/ contato vidro	0,901	PE-12.11
BS-632E	Travessa inferior	0,945	PE-6.11	FA-267	Luva para o perfil FA-236	1,196	PE-12.16
BS-699E	Contramarco periférico	0,391	PE-2.01	FA-268	Luva para o perfil FA-236	0,840	PE-12.16
BS-726E	Marco superior bandeira / inferior peitoral	0,526	PE-6.02	FA-269	Arremate interno coluna 90° externo glazing	0,684	PE-12.11
BS-729E	Travessa intermediária para bandeira 2 planos	1,106	PE-6.02	FA-270	Perfil para ancoragem FAA-217 e FAA-302	2,930	PE-12.12
BS-731E	Baguete horizontal	0,110	PE-6.12	FA-271	Perfil para ancoragem FAA-217 e FAA-302	1,626	PE-12.12
BS-732E	Baguete horizontal	0,156	PE-6.12	FA-275	Luva telescópica para coluna FA-244	1,684	PE-12.17
BS-737	Travessa com olhal	0,596	PE-6.13	FA-276	Trav. folha móvel c/ guia p/ varão cremona-SG	0,794	PE-12.09
BS-738	Travessa intermediária	0,517	PE-6.13	FA-278	Marco lateral para coluna FA-375	1,453	PE-12.07
BS-739A	Pingadeira	0,144	PE-6.13	FA-279	Luva para marco lateral FA-278	1,826	PE-12.14
BS-751	Travessa superior do maxim-ar	0,332	PE-6.13	FA-291	Marco de ligação porta L 42	0,875	PE-12.09
BS-752A	Travessa superior do maxim-ar com olhal	0,370	PE-6.13	FA-293	Arremate intermediário soleira / lumieira	0,518	PE-12.11
BS-753E	Marco lateral	0,386	PE-6.03	FA-294	Marco periférico p/ coluna FA-204 / FA-205	0,785	PE-12.06
BS-755	Pingadeira travessa inferior da folha	0,127	PE-6.14	FA-299	Tampa do arremate FA-265 soleira / lumieira	0,218	PE-12.11
BS-779	Travessa superior da folha maxim-ar	0,370	PE-6.14	FA-300	Tampa do arremate FA-265	0,843	PE-12.11
E-560E	Trilho Stanley	0,635	PE-5.01	FA-325	Arremate soleira / lumieira	0,653	PE-12.11
E-565E	Veneziana	0,397	PE-3.01	FA-326	Tampa do arremate FA-325 - soleira / lumieira	0,103	PE-12.11
FA-200	Coluna central com 92 mm	1,952	PE-12.01	FA-333	Marco lateral com 180 mm	2,106	PE-12.07
FA-204	Coluna central com olhal 38 mm	1,010	PE-12.01	FA-334	Luva para o perfil FA-333	2,236	PE-12.15
FA-208	Luva tubular com olhal para FA-202 / FA-205	0,754	PE-12.15	FA-336	Luva para coluna FA-360	1,378	PE-12.16
FA-211	Travessa intermediária	0,993	PE-12.08	FA-347	Marco para coluna com 70 mm	1,330	PE-12.06
FA-223	Luva com olhal para coluna FA-200	1,978	PE-12.13	FA-360	Coluna de canto 90° externo	3,912	PE-12.05
FA-226E	Ancoragem central p/ FA-200/FA-202/FA-375	3,939	PE-12.12	FA-361	Luva para coluna FA-360	1,560	PE-12.16
FA-228	Montante do módulo fixo glazing SG-51S	0,568	PE-12.09	FA-375	Coluna central com 120 mm	2,454	PE-12.02
FA-230	Travessa superior / inferior folha móvel glazing	0,777	PE-12.09	FA-376	Luva para perfil FA-375	2,285	PE-12.14
FA-231A	Presilha de apoio inferior modulo SG-50	0,384	PE-12.08	FA-390	Coluna central com 180 mm - Bitubular	3,630	PE-12.02
FA-232	Travessa superior / inferior modulo fixo glazing	0,603	PE-12.09	FA-391	Luva para o perfil FA-390	2,621	PE-12.15
FA-236	Coluna 90° externo	2,364	PE-12.03	FA-400	Coluna central com 70mm	1,488	PE-12.01
FA-239A	Arremate intermediário - soleira / lumieira	0,582	PE-12.11	FA-401	Luva para coluna FA-400	1,727	PE-12.13
FA-240	Presilha do complemento soleira / lumieira	0,135	PE-12.08	FA-403	Montante da folha móvel	0,634	PE-12.10
FA-244	Coluna central com ângulo interno de 135°	1,824	PE-12.04	FA-404	Montante do módulo fixo	0,540	PE-12.10
FA-245	Montante da folha sem olhal - Glazing SG	0,742	PE-12.09	FA-405	Travessa superior da folha móvel	0,669	PE-12.10
FA-247	Perfil para presilha FAA-205	0,210	PE-12.08	FA-406	Travessa superior / inferior do módulo fixo	0,574	PE-12.10

perfil	descrição	peso (kg/m)	página	perfil	descrição	peso (kg/m)	página
FA-511	Marco lat. p/ colunas FA-200 / FA-202 / FA-262	1,318	PE-12.06	PU-112	Perfil U 26,00 x 3,00	0,583	PE-1.01
FA-512	Telescópico	0,521	PE-12.06	SC-2029	Tampa interna da caixa da persiana integrada	0,883	PE-8.05
FA-517	Luva telescópica p/ marcos FA-294 / FA-516	0,613	PE-12.14	SC-2034	Montante lateral para guiagem da persiana	0,514	PE-8.03
GS-043	Coluna central retangular	1,067	PE-10.01	SC-2080	Coluna para divisão e guiagem da persiana	1,141	PE-8.03
GS-044	Pontaletes para coluna central retangular	1,376	PE-10.01	SC-2088	Arremate lat. recolhedor da persiana integrada	0,942	PE-8.03
GS-055	Perfil periférico do vidro	0,481	PE-10.01	SC-2139	Marco lateral da persiana integrada	0,561	PE-8.03
GS-063	Luva para corrimão GS-066	0,601	PE-10.01	SC-2186	Tampa interna da caixa integrada porta	0,692	PE-8.06
GS-066	Corrimão	1,227	PE-10.01	SC-2187	Tampa interna da caixa integrada porta	0,763	PE-8.06
KBV-010	Tampa	0,070	PE-9.02	SI-2509	Mata junta	0,229	PE-6.03
LS-4501	Baguete vertical	0,164	PE-9.02	SI-2510	Travessa intermediária da persiana integrada	1,168	PE-8.01
LS-4502	Baguete horizontal	0,152	PE-9.02	SI-2521	Marco inferior 2 planos	0,705	PE-6.01
LS-4504	Marco periférico	1,435	PE-9.01	SI-2523	Marco inferior 2 planos para porta	0,650	PE-6.01
LS-4505	Marco periférico complementar	0,881	PE-9.01	SI-2525A	Trilho inferior para persiana integrada	0,954	PE-8.01
LS-4506	Perfil complementar do trilho	0,097	PE-9.01	SI-2527	Montante lateral	0,512	PE-6.07
LS-4507	Perfil periférico da folha	1,744	PE-9.02	SI-2529	Montante lat. p/ fechadura c/ reforço interno	0,697	PE-6.07
LS-4508	Reforço para folhas	1,172	PE-9.02	SI-2530	Montante lat. p/ fechadura c/ reforço int. e ext.	0,975	PE-6.07
LS-4509	Pingadeira	0,199	PE-9.01	SI-2531	Montante simples c/ engate externo	0,505	PE-6.07
LS-4510	Haste de comando	0,118	PE-5.01	SI-2532	Montante simples c/ engate interno	0,505	PE-6.07
LS-4531	Perfil de engate	0,511	PE-9.02	SI-2533	Montante de engate externo c/ reforço tubular	1,037	PE-6.08
LS-4532	Fechamento	0,152	PE-9.02	SI-2534	Montante de engate interno c/ reforço tubular	1,001	PE-6.08
PL-152	Cantoneira 12,7 x 1,58	0,102	PE-1.01	SI-2535	Montante lateral	0,535	PE-6.09
PL-155	Cantoneira 15,87 x 1,58	0,130	PE-1.01	SI-2537	Montante lateral com reforço	1,040	PE-6.09
PL-157	Cantoneira 19,05 x 1,58	0,157	PE-1.01	SI-2538	Montante central com engate	0,551	PE-6.09
PL-160	Cantoneira 22,22 x 2,38	0,271	PE-1.01	SI-2539	Montante central c/ engate e reforço p/ porta	1,046	PE-6.09
PL-162	Cantoneira 25,4 x 1,58	0,212	PE-1.01	SI-2540	Montante de engate duplo para janela	0,656	PE-6.10
PL-163	Cantoneira 25,4 x 3,17	0,410	PE-1.01	SI-2541	Marco inferior 2 planos	0,791	PE-6.01
PL-167	Cantoneira 38,10 x 3,17	0,628	PE-1.01	SI-2542	Travessa intermediária para peitoril 2 planos	1,150	PE-6.02
PL-169	Cantoneira 50,80 x 3,17	0,847	PE-1.01	SI-2567	Montante central com engate duplo	0,612	PE-6.07
PL-183E	Cantoneira 50,80 x 2,50	0,671	PE-1.01	SI-2568	Trilho individual	0,360	PE-6.01
PL-228	Cantoneira 38,10 x 1,58	0,321	PE-1.01	SI-2569	Marco inferior - 4 planos	1,445	PE-6.06
PL-255	Cantoneira 50,80 x 25,40 x 3,17	0,625	PE-1.01	SI-2572	Perfil de vedação sup. e inf. dos montantes	0,328	PE-6.10
PU-101	Perfil U 9,52 x 1,58	0,108	PE-1.01	SI-2574E	Coluna central	0,907	PE-6.03
PU-102	Perfil U 12,70 x 1,58	0,149	PE-1.01	SI-2576E	Marco superior - 4 planos	1,585	PE-6.06
PU-104	Perfil U 16,00 x 1,50	0,182	PE-1.01	SI-2577E	Marco lateral - 4 planos	0,917	PE-6.06

perfil	descrição	peso (kg/m)	página	perfil	descrição	peso (kg/m)	página
SI-2578	Marco superior da persiana integrada	0,748	PE-8.01	SI-3523S	Travessa intermediária / bandeira 2 planos	1,924	PE-7.03
SI-2586	Montante central com reforço para porta	1,131	PE-6.08	SI-3525S	Marco lateral liso p/ bandeira 2 planos	0,557	PE-7.02
SI-2593	Montante lateral para janela	0,518	PE-6.10	SI-3526S	Marco superior / inferior 2 planos	0,657	PE-7.03
SI-2596	Montante lateral com reforço duplo para porta	0,698	PE-6.10	SI-3560S	Marco lateral 4 planos	1,394	PE-7.06
SI-2597	Montante com engate duplo para porta	0,624	PE-6.10	SI-3561S	Trilho inf. 4 planos c/ complemento	1,932	PE-7.05
SI-2598	Montante central com engate para porta	0,525	PE-6.10	SI-3562S	Trilho superior de 4 planos	2,063	PE-7.05
SI-2600	Montante central c/ engate e reforço p/ porta	0,827	PE-6.08	SI-3563S	Trilho individual c/ complemento	0,352	PE-7.01
SI-2603	Montante central c/ engate e reforço p/ porta	1,021	PE-6.10	SI-3564S	Trilho inf 2 planos com complemento	0,986	PE-7.01
SI-2604	Perfil de arremate da veneziana vertical	0,101	PE-6.12	SI-3565S	Trilho inf. 3 planos c/ complemento	1,460	PE-7.04
SI-2605	Perfil de arremate da veneziana horizontal	0,107	PE-6.12	SI-3579S	Marco periférico	0,386	PE-7.11
SI-2606	Mata junta	0,264	PE-6.03	SI-3580	Coluna central	0,667	PE-7.12
SI-2608	Veneziana	0,254	PE-3.02	SI-3581	Travessa intermediária	0,586	PE-7.12
SI-2608V	Veneziana ventilada	0,254	PE-3.02	SI-3591S	Marco inferior 2 planos c/ complemento	1,150	PE-7.01
SI-2609	Veneziana	0,236	PE-3.02	SI-3592S	Trav. interm. peitoril 2 planos c/ complemento	1,895	PE-7.03
SI-2609V	Veneziana ventilada	0,236	PE-3.02	SI-3593S	Marco inferior persiana integrada 146 mm	1,518	PE-8.02
SI-2613E	Marco para porta de giro	0,453	PE-6.15	SI-3595S	Marco lateral 3 planos com mata junta central	0,936	PE-7.06
SI-2615	Montante para porta de giro	0,635	PE-6.15	SI-3596S	Marco lateral 3 planos base reta c/ mata junta	1,041	PE-7.06
SI-2616	Montante para porta de giro	0,653	PE-6.15	SI-3597S	Marco inferior 3 planos c/ complemento	1,612	PE-7.04
SI-2618	Montante e travessa inferior da folha	0,431	PE-6.13	SI-3604S	Perfil periférico folha com bagueete	0,599	PE-7.11
SI-2619	Montante e travessa inferior da folha	0,474	PE-6.14	SI-3607	Fixador da travessa	0,493	PE-7.12
SI-2620	Marco maxim-ar	0,351	PE-6.13	SI-3634	Bagueete vertical	0,141	PE-7.11
SI-2621	Marco inferior 3 planos	0,989	PE-6.04	SI-3636S	Montante lateral	0,868	PE-7.07
SI-2622	Marco inferior 3 planos para porta	0,922	PE-6.04	SI-3637S	Montante central com engate	0,829	PE-7.07
SI-2624	Mata junta para porta de giro	0,220	PE-6.15	SI-3638S	Montante central com engate	0,829	PE-7.07
SI-2642	Terminal da palheta SI-2608	0,108	PE-6.11	SI-3639S	Travessa superior e inferior	0,735	PE-7.07
SI-3501S	Marco superior 2 planos	1,123	PE-7.01	SI-3642S	Montante lateral com reforço	1,085	PE-7.08
SI-3502S	Porta palheta veneziana vertical	0,141	PE-7.12	SI-3643S	Travessa inferior da folha com 100mm	1,185	PE-7.07
SI-3503S	Marco lateral 2 planos	0,721	PE-7.02	SI-3644S	Vedação superior e inferior dos montantes	0,366	PE-7.10
SI-3504S	Travessa intermediária da persiana integrada	2,030	PE-8.02	SI-3647S	Montante lateral	0,987	PE-7.09
SI-3515S	Marco superior tubular 3 planos	1,557	PE-7.04	SI-3648S	Montante central com engate	0,949	PE-7.09
SI-3518S	Travessa intermediária	0,726	PE-7.11	SI-3649S	Travessa superior e inferior da folha	0,805	PE-7.09
SI-3519S	Perfil periférico do quadro maxim-ar	0,438	PE-7.11	SI-3650S	Travessa inferior da folha	1,254	PE-7.09
SI-3520	Coluna	1,131	PE-7.02	SI-3651S	Travessa intermediária da folha	0,858	PE-7.09
SI-3521S	Travessa intermediária	0,312	PE-7.11	SI-3652S	Montante lateral com reforço	1,164	PE-7.10

perfil	descrição	peso (kg/m)	página	perfil	descrição	peso (kg/m)	página
SI-3655S	Montante lateral e central c/ reforço	1,435	PE-7.08	TQ-031	Tubo quadrado 15,9 x 1,50	0,233	PE-1.02
SI-3659S	Montante lateral com reforço	1,512	PE-7.10	TQ-056	Tubo quadrado 101,60 x 2,50	2,686	PE-1.02
SI-3663	Baguete horizontal para linha 90°	0,152	PE-7.11	TR-049	Tubo redondo 15,87 x 1,58	0,191	PE-1.02
SI-3664S	Travessa intermediária com baguete	0,716	PE-7.07	TR-053	Tubo redondo 19,05 x 1,58	0,234	PE-1.02
SI-3667	Arremate	0,308	PE-2.02	TR-058	Tubo redondo 22,22 x 1,58	0,276	PE-1.02
SI-3669	Presilha do arremate SI-3667	0,328	PE-2.02	TR-061	Tubo redondo 25,40 x 1,58	0,319	PE-1.02
SI-3677	Mata junta para porta de giro	0,331	PE-7.13	TR-075	Tubo redondo 38,10 x 1,58	0,489	PE-1.02
SI-3678S	Marco periférico para porta de giro	0,684	PE-7.13	TR-085E	Tubo redondo 50,80 x 1,60	0,670	PE-1.02
SI-3679	Montante para porta de giro	0,873	PE-7.13	TR-099	Tubo redondo 76,20 x 2,00	1,263	PE-1.02
SI-3715S	Perfil para caixilho fixo com baguete	0,436	PE-7.11				
SI-3716	Mata junta central	0,226	PE-9.02				
SI-3718	Baguete periférico vidro duplo	0,132	PE-7.11				
SI-3719S	Perfil complemento dos trilhos (Anodizado)	0,066	PE-7.01				
SI-3724	Mata junta	0,309	PE-7.01				
SI-3733	Porta palheta veneziana horizontal	0,169	PE-7.12				
SI-3742	Montante da folha p/ porta de giro - 100 mm	1,095	PE-7.13				
SI-3743	Montante central c/ engate e reforço interno	1,546	PE-7.08				
SI-3744	Montante central c/ engate e reforço externo	1,546	PE-7.08				
SI-3745	Montante central com engate e reforço	1,649	PE-7.10				
SI-3748	Perfil de vedação sup. e inf. dos montantes	0,236	PE-9.01				
TG-036	Tubo retangular 101,60 x 50,80 x 2,00	1,603	PE-1.02				
TG-038	Tubo retangular 76,20 x 38,10 x 1,50	0,902	PE-1.02				
TG-039E	Tubo retangular 101,60 x 38,10 x 2,40	1,754	PE-1.02				
TG-041	Tubo retangular 50,80 x 25,40 x 1,00	0,400	PE-1.02				
TG-044	Tubo retangular 50,80 x 25,40 x 1,58	0,623	PE-1.02				
TG-046E	Tubo retangular 152,40 x 50,80 x 3,00	3,206	PE-1.02				
TG-060	Tubo retangular 25,40 x 12,70 x 1,58	0,298	PE-1.02				
TG-075	Tubo retangular 50,80 x 12,70 x 1,50	0,490	PE-1.02				
TQ-001	Tubo quadrado 12,70 x 1,58	0,190	PE-1.02				
TQ-009	Tubo quadrado 19,05 x 1,50	0,284	PE-1.02				
TQ-012	Tubo quadrado 25,40 x 1,50	0,387	PE-1.02				
TQ-015	Tubo quadrado 38,10 x 1,50	0,593	PE-1.02				
TQ-017	Tubo quadrado - 50,80 x 2,00	1,054	PE-1.02				
TQ-020	Tubo quadrado 76,20 x 2,00	1,603	PE-1.02				